

NEXT-G GAS CHANGE

1 PREMISE

1.1 QR CODE



1.2 AVAILABLE LANGUAGES

This document is originally written in Italian and English. Any other languages are translations of this document. For versions of this document in other languages, see Robur website.

1.3 USE

Next-G series gas unit heaters.

1.4 KEY TO SYMBOLS



DANGER



WARNING



NOTE



PROCEDURE



REFERENCE (to other document)

2 WARNINGS



For correct installation, please refer to the manual included in the appliance and to these assembly instructions.



Please read the warnings and operating instructions contained in these instructions carefully as they provide important information regarding safe installation, use and maintenance. Keep this sheet carefully for further reference. The manufacturer cannot be held responsible for any damage caused by improper, erroneous or unreasonable use.



Installer's qualifications

Installation must exclusively be performed by a qualified firm and by skilled personnel, with specific knowledge on heating, electrical systems and gas appliances, in compliance with the laws in force in the Country of installation.

The design, installation, operation and maintenance of the systems shall be carried out in compliance with current applicable regulations, depending on the Country and location, and in accordance with the manufacturer's instructions. In particular, regulations regarding the following shall be complied with:

► Gas systems and equipment.
 ► Electrical systems and equipment.
 ► Heating systems.
 ► Environmental protection and combustion products exhaust.
 ► Fire safety and prevention.
 ► Any other applicable law, standard and regulation.



Any contractual or extra-contractual liability of the manufacturer for any damage caused by incorrect installation and/or improper use and/or failure to comply with regulations and with the manufacturer's directions/instructions shall be disclaimed.



This operation must be carried out in total safety. Before starting intercept the gas and disconnect the power supply.

3 GAS CHANGEOVER



The operations described must only be carried out by an authorised service centre.



After the gas changeover, check the combustion parameters as described in Paragraph 5 p. 4.



The following instructions apply to both the conversion from natural gas (G20) to any other gas and vice versa.



After the gas change, replace the sticker indicating the gas type on the appliance with the sticker for the new gas type.



Check that the gas supply line is suitable for the new fuel type used to supply the unit.

The following Table 3.1 p. 2 shows the nozzle diameter and code for the different gas unit heater models, depending on the gas type.

Table 3.1 Nozzle data

			G 20 EC	G 30	G 35 EC	G 45	G 60	G 75 EC	G 90	
Installation data										
Nozzle	Diameter (Ø)	G20	mm	6,00	9,50	8,40	9,50	9,80		10,10
	Code	G20	-	209	211	272	211	276	282	277
	Diameter (Ø)	G25	mm	6,00	9,50	8,40	9,50	9,80	10,20	11,20
	Code	G25	-	209	211	272	211	276	283	247
	Diameter (Ø)	G25.1	mm	6,80	10,80	10,10	12,30	- (1)	11,00	11,40
	Code	G25.1	-	216	287	273	218	- (1)	246	221
	Diameter (Ø)	G25.3	mm	6,00	9,50	8,40	9,50	9,80	10,50	11,20
	Code	G25.3	-	209	211	272	211	276	284	278
	Diameter (Ø)	G27	mm	6,80	10,80	10,10	10,70	- (1)	11,30	11,90
	Code	G27	-	216	287	273	274	- (1)	285	281
	Diameter (Ø)	G2.350	mm	6,80	- (1)	10,10	- (1)		- (2)	
	Code	G2.350	-	216	- (1)	273	- (1)		- (2)	
	Diameter (Ø)	G30	mm	4,30	5,40	5,50		5,80	7,00	7,50
	Code	G30	-	271	288	275		202	239	279
	Diameter (Ø)	G31	mm	4,30	5,40	5,50		5,80	7,80	8,10
	Code	G31	-	271	288	275		202	241	224
	Diameter (Ø)	LPG	mm	4,30	5,40	5,50		5,80	7,50	7,70
	Code	LPG	-	271	288	275		202	279	280

(1) Operation with this type of gas does not require the use of the nozzle.
 (2) The gas unit heater cannot operate with this type of gas.

3.1 G 20, G 30, G 35, G 45, G 60



How to change gas (Figure 3.1 p. 2)

- Cut off electric power and gas supply.
- Unscrew the hexagonal seal that connects the gas pipe (A) to the nozzle holder fitting. Take care not to lose or damage the internal gasket (B) nor the o-ring (D).
- Move the gas pipe and pull out the nozzle (C), using a screwdriver if necessary.
- Remove the gasket (B) and o-ring (D) from the old nozzle and mount it on the new nozzle.
- Insert the new nozzle into its seat, checking the concordance with Table 3.1 p. 2.
 - For the G 30 gas unit heater only, and only when fed with G2.350 gas, the existing nozzle must be removed.
- For the G 45 gas unit heater only, and only when fed with G2.350 gas, the existing nozzle must be removed.
- For the G 60 gas unit heater only, and only when fed with G25.1, G27 and G2.350 gas, the existing nozzle must be removed.
- Check whether the blower air diaphragm also needs to be replaced (Paragraph 3.3 p. 3).
- Reassemble the gas pipe, checking that the round gasket in the seal is well positioned. Close the seal applying a torque of 62±2 Nm.
- Enter menu 5, password 2-2-2, set parameter 43 according to gas type: natural gas (0) / LPG (1).
- Adjust the appliance for the new gas type, adjusting the burner pressure as described in Paragraph 5.1 p. 5.
- Replace the sticker indicating the gas type on the appliance with the sticker for the new gas type.

Figure 3.1 Gas changeover for gas unit heater

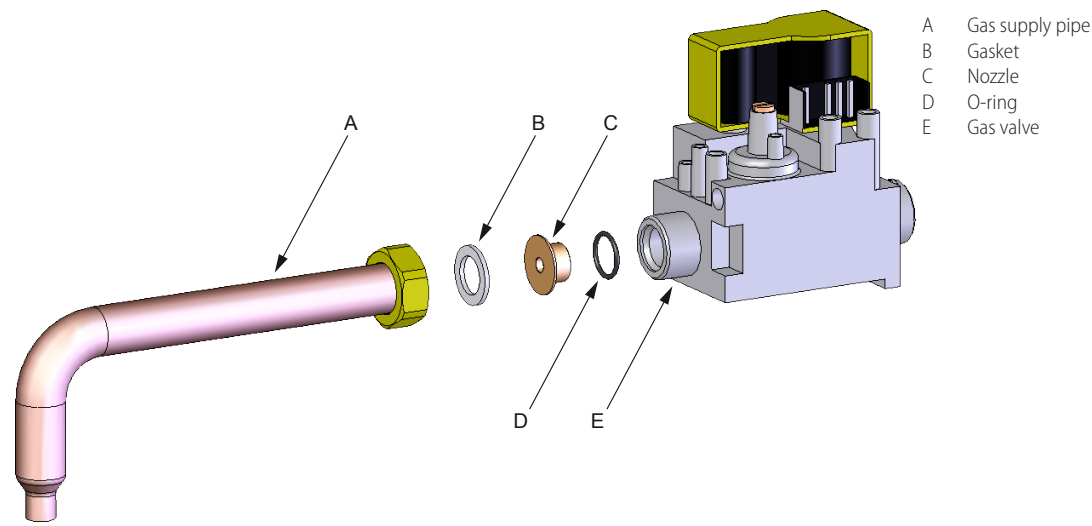

3.2 G 75, G 90



How to change gas (Figure 3.2 p. 3)

1. Cut off electric power and gas supply.
2. Remove the gas pipe (A) and remove the gasket (B).
3. Unscrew the four fixing screws (C) of the gas flange (D) and remove it without losing or damaging the o-ring (E).
4. Remove the gasket (F), taking care not to damage or lose it.

5. Replace the nozzle (G), checking the concordance with Table 3.1 p. 2, and reinstall the gasket (F).
6. Fit the gas flange (D) using the four fixing screws (C) and fit the gas pipe (A), replacing the gasket (B).
7. Enter menu 5, password 2-2-2-2, set parameter 43 according to gas type: natural gas (0) / LPG (1).
8. Adjust the appliance for the new gas type, adjusting the burner pressure as described in Paragraph 5.2 p. 7.
9. Replace the sticker indicating the gas type on the appliance with the sticker for the new gas type.

Figure 3.2 Gas changeover for gas unit heater

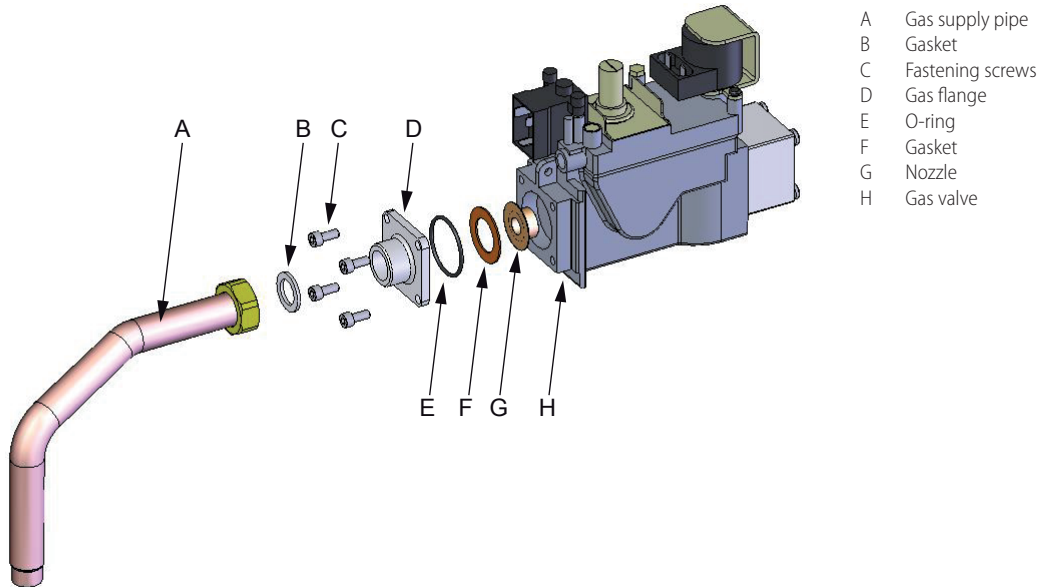

3.3 BLOWER DIAPHRAGM REPLACEMENT

When switching to specific types of gas for specific gas unit heaters, it may be necessary to replace the blower air diaphragm.

Figure 3.3 Blower diaphragm replacement

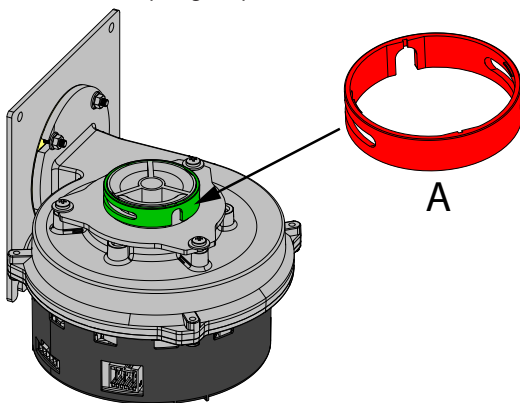

A Diaphragm supplied for the specific combination of gas unit heater type and gas type

3.3.1 G 30

For the conversion from G20/G25/G25.1/G25.3/G27/G2.350 gas to G30/G31/LPG gas, the green air diaphragm must be removed and replaced with the supplied red air diaphragm.

3.3.2 G 35

For the conversion from G20/G25/G25.3/G30/G31/LPG gas to G25.1/G27/G2.350 gas, the green air diaphragm must be removed and replaced with the supplied red air diaphragm.

3.3.3 G 45

For the conversion from G20/G25/G25.1/G25.3/G27/G2.350 gas to G30/G31/LPG gas, the blue air diaphragm must be removed and replaced with the supplied green air diaphragm.

3.3.4 G 60

For the conversion from G20 gas to G25/G30/G31/LPG gas, the supplied blue air diaphragm must be installed.
For the conversion from G20 gas to G25.1/G2.350 gas, the supplied green air diaphragm must be installed.

4 SUPPLY GAS PRESSURE

This appliance is equipped for a maximum gas supply pressure of 50 mbar.

The appliance's gas supply pressure, both static and dynamic,

must comply with Table 4.1 p. 4, with tolerance $\pm 15\%$.

Non compliant gas pressure may damage the appliance and be hazardous.



The Next-G gas unit heaters are also approved for use

with I20 gas, i.e. a gas mix with a 20% maximum of hydrogen.

Table 4.1 Network gas pressure of Next-G series gas unit heaters

Product category	Country of destination	Gas supply pressure [mbar]								
		G20	G25	G25.1	G25.3	G2.350 (1)	G27	G30	G31	
I ₂ H3B/P	AL, BG, CH, CY, CZ, DK, EE, FI, GR, HR, IT, LT, LV, MK, NO, RO, SE, SI, SK, TR	20						30	30	
	AT, CH	20						50	50	
I ₂ H3P	AL, BG, CH, CZ, ES, GB, GR, HR, IE, IT, LT, LV, MK, PT, SI, SK, TR	20							37	
	RO	20							30	
	AT	20							50	
I ₂ ELL3B/P	DE	20	20					50	50	
I ₂ ES3P	FR	20	25						37	
		20	25						37	
I ₂ H3B/P	HU	25						30	30	
I ₂ HS3B/P		25		25				30	30	
I ₂ E3P	LU	20							50	
I ₂ L3B/P	NL		25						30	30
I ₂ L3P			25						37	
I ₂ EK3B/P		20			25			30	30	
I ₂ EK3P		20			25				30	
I ₂ E3B/P	PL	20						37	37	
I ₂ E		20								
I ₂ ELwLs3B/P		20				13	20	37	37	
I ₂ ELwLs3P		20				13	20		37	
I ₂ E(R)	BE	20	25							
I ₂ E(S)		20	25							
I ₃ P									37	
I ₃ P	IS								30	
I ₂ H	LV	20								
I ₃ B/P	MT							30	30	
								30		

¹ The G 75 and G 90 gas unit heaters cannot be operated with this type of gas. The appliance gas supply pressure, both static and dynamic, must comply with the values in the Table, with a tolerance of ± 15%.

5 COMBUSTION PARAMETERS CHECK



Paragraph reserved exclusively to TACs.



The gas unit heater is supplied with the gas valve already calibrated with respect to the fuel indicated on the sticker next to the gas connection. Therefore, during the commissioning, only the CO₂ value must be checked and, only if the check is not successful, or after a gas changeover, the complete check procedure must be carried out.



The CO₂ value should be checked with the thermoformed door closed, while the gas valve should be adjusted with the thermoformed door open.



After each setting of the CO₂ value or change of power level, check the burner, which should not show any redened areas.



Check that the static and dynamic supply gas pressure values, with the gas unit heater running at maximum power, correspond to what is shown in Table 4.1 p. 4

(with low supply gas pressure values the CO₂ value will also be at minimum values).



The operation request for checking combustion parameters is independent of any heating service requests on the "HEAT" contact.

Table 5.1 p. 5 shows the messages that can appear on the display while the chimney sweep function is running, the relative meaning and the optional actions required.



Limit the time you use the chimney sweep function to the minimum actually required.





The system automatically interrupts the chimney sweep function 15 minutes after the last key on the interface was pressed.



If the required CO₂ settings cannot be reached, contact Robur.

Table 5.1 Display messages for chimney sweep function

Message	Meaning	Action
CS.LO / UAIt	Chimney sweep function is active at minimum capacity and the flame is still not lit or lit at a different capacity than required.	Wait.
CS.LO / _GO_	Chimney sweep function is active at minimum capacity and the flame is lit at the required capacity.	Run CO ₂ reading (minimum capacity).
CS.HI / UAIt	Chimney sweep function is active at maximum capacity and the flame is still not lit or lit at a different capacity than required.	Wait.
CS.HI / _GO_	Chimney sweep function is active at maximum capacity and the flame is lit at the required capacity.	Run CO ₂ reading (maximum capacity).
Err.	The appliance switched off due to a fault (Warning or Error).	It is not possible to reset any errors with the function active. Deactivate the function by pressing the  key for 5 seconds and then intervene according to the operating codes shown on the display, while referring operative codes table. Once the problem is resolved, reactivate the function.
Cod.x (x = 0, 1,..)	The appliance is temporarily running a special cycle that requires specific control of the power that is not compatible with the execution of the chimney sweep function.	In the rare event of one of these codes appearing, deactivate the function by pressing the  key for 5 seconds and then contact Robur.



5.1 ALL MODELS EXCEPT G 75 AND G 90



The simple check of CO₂ values corresponds to steps 8 to 15 of the procedure below, after turning on the unit. If the check is not successful, the complete procedure must be carried out.



Figure 5.1 p. 5

- If the appliance is running, switch it off with the applicable control system.
- Open the thermoformed door.
- Remove the cap over the offset adjustment screw (C) of the gas valve.
- Screw in completely the throttle adjustment screw (D).
- Screw in completely the offset adjustment screw (C).
- Unscrew the throttle adjustment screw (D) as indicated in the following Tables, depending on the model and the gas type used.
- Unscrew the offset adjustment screw (C) as indicated in the following Tables, depending on the model and the gas type used.
- Press the  key on the user interface of the appliance for 5 seconds to activate the chimney sweep function at minimum power.
- The display shows the letters "CS.LO" (chimney sweep low power), alternating with the flashing message "UAIt" (wait) which indicates that the machine is not yet ready for the reading.
- After up to 8 minutes the flashing message becomes "_GO_" to indicate that the combustion control can be carried out.
- Ensure that the CO₂ value corresponds to the value indicated in the "Minimal heat input" column of the following Tables, according to the model and the gas type used. Otherwise, set CO₂ percentage value using the offset adjustment screw.
- Press the  key on the user interface to activate the chimney sweep function at maximum power.
- The display shows the letters "CS.HI" (chimney sweep high power), alternating once again with the flashing message "UAIt" (wait) which indicates that the machine is not yet ready for the reading.

- After a short while, the flashing message becomes "_GO_" again to indicate that the combustion control at maximum power can be carried out.
- Ensure that the CO₂ value corresponds to the value indicated in the "Nominal heat input" column of the following Tables, according to the model and the gas type used. Otherwise, set CO₂ percentage value using the throttle adjustment screw.

If the check is successful:

- Press the  key on the user interface again for 5 seconds to deactivate the chimney sweep function and complete the procedure.
- Screw the cap back over the offset adjustment screw (C) of the gas valve.
- Close the thermoformed door.

If the check is not successful:

- Repeat the checking procedure, at the minimum heat input or at the maximum heat input, until CO₂ values corresponding to those indicated in the following Tables are achieved, according to the model and the type of gas used.
- Repeat steps 16 to 18 to complete the procedure.

Figure 5.1 Gas valve

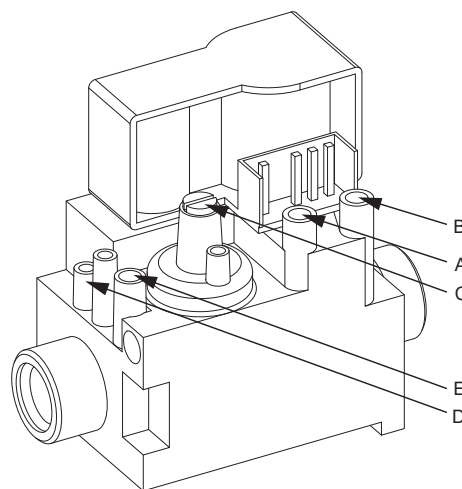

- A Offset pressure intake
- B Gas mains pressure intake
- C Offset adjustment screw
- D Throttle adjustment screw
- E Throttle pressure intake

Table 5.2 Next-G 20 gas valve setting table

Gas	Gas network pressure	Screw pre-adjustment		CO ₂ percentage in flue gases	
		Throttle	Offset	Minimal heat input	Nominal heat input
Type	mbar	turns	turns	%	%
G20	See Table 4.1 p. 4	-5 ¾	-4 ½	8,5	9,3
G25		full open	-4 ½	8,8	9,2
G25.1		-6 ¾	-4 ½	10,2	10,5
G25.3		-11 ¼	-4 ½	9,0	9,4
G27		-6 ¾	-4 ½	8,8	9,0
G2.350		full open	-4 ½	8,7	9,0
G30		-3 ¾	-4 ½	10,2	10,5
G31		full open	-4 ½	10,4	10,7
LPG		-4	-4 ½	10,3	10,6

A tolerance of ±0,3% is applied to all values of CO₂ percentage in fumes.

Table 5.3 Next-G 30 gas valve setting table

Gas	Gas network pressure	Screw pre-adjustment		CO ₂ percentage in flue gases	
		Throttle	Offset	Minimal heat input	Nominal heat input
Type	mbar	turns	turns	%	%
G20	See Table 4.1 p. 4	-7 ¾	-6 ¼	8,1	9,5
G25		full open	-6 ¼	8,1	9,7
G25.1		-6	-6 ¼	9,1	10,9
G25.3		-8 ½	-6 ¼	8,1	9,6
G27		-6	-6 ¼	8,0	9,3
G2.350		full open	-6 ¼	7,8	9,4
G30		-5 ¾	-6 ¼	8,9	10,5
G31		full open	-6 ¼	8,3	10,3
LPG		-9 ½	-6 ¼	8,8	10,2

A tolerance of ±0,3% is applied to all values of CO₂ percentage in fumes.

Table 5.4 Next-G 35 gas valve setting table

Gas	Gas network pressure	Screw pre-adjustment		CO ₂ percentage in flue gases	
		Throttle	Offset	Minimal heat input	Nominal heat input
Type	mbar	turns	turns	%	%
G20	See Table 4.1 p. 4	-7 ½	-4 ½	8,6	9,2
G25		full open	-4 ½	8,2	8,9
G25.1		-8 ½	-4 ½	10,8	11,5
G25.3		full open	-4 ½	8,6	9,2
G27		-8 ½	-4 ½	9,4	9,8
G2.350		full open	-4 ½	8,8	9,4
G30		-6 ¼	-4 ½	10,1	10,3
G31		full open	-4 ½	9,6	10,1
LPG		-6 ½	-4 ½	9,8	10,2

A tolerance of ±0,3% is applied to all values of CO₂ percentage in fumes.

Table 5.5 Next-G 45 gas valve setting table

Gas	Gas network pressure	Screw pre-adjustment		CO ₂ percentage in flue gases	
		Throttle	Offset	Minimal heat input	Nominal heat input
Type	mbar	turns	turns	%	%
G20	See Table 4.1 p. 4	-7 ¾	-5 ¾	8,1	8,7
G25		full open	-5 ¾	8,1	9,1
G25.1		-10 ¼	-5 ¾	9,4	10,3
G25.3		-8 ¼	-5 ¾	8,2	9,0
G27		-11 ¾	-5 ¾	8,0	8,9
G2.350		full open	-5 ¾	7,8	8,4
G30		-5 ¾	-5 ¾	9,3	10,0
G31		full open	-5 ¾	9,6	9,9
LPG		-6 ¾	-5 ¾	9,4	10,0

A tolerance of ±0,3% is applied to all values of CO₂ percentage in fumes.

Table 5.6 Next-G 60 gas valve setting table

Gas	Gas network pressure	Screw pre-adjustment		CO ₂ percentage in flue gases	
		Throttle	Offset	Minimal heat input	Nominal heat input
Type	mbar	turns ↻	turns ↻	%	%
G20	See Table 4.1 p. 4	-8 ¼	-5 ¼	8,1	8,7
G25		full open	-5 ¼	8,0	8,8
G25.1		-7 ½	-5 ½	11,7	11,9
G25.3		full open	-5 ¼	8,2	9,0
G27		-12 ¾	-5 ¼	7,9	8,9
G2.350		full open	-5 ¼	8,1	9,3
G30		-6	-5 ¼	9,8	10,2
G31		full open	-5 ¼	9,4	9,9
LPG		-6 ¼	-5 ¼	9,6	10,1

A tolerance of ±0,3% is applied to all values of CO₂ percentage in fumes.

5.2 G 75, G 90



The simple check of CO₂ values corresponds to steps 6 to 13 of the procedure below, after turning on the unit. If the check is not successful, the complete procedure must be carried out.



Figure 5.2 p. 7

- If the appliance is running, switch it off with the applicable control system.
- Open the thermoformed door.
- Remove the cap over the offset adjustment screw (C) of the gas valve.
- Screw in completely the offset adjustment screw (C).
- Unscrew the offset adjustment screw (C) as indicated in the following Tables, depending on the model and the gas type used.
- Press the key on the user interface of the appliance for 5 seconds to activate the chimney sweep function at minimum power.
- The display shows the letters "CS.LO" (chimney sweep low power), alternating with the flashing message "UAIt" (wait) which indicates that the machine is not yet ready for the reading.
- After up to 8 minutes the flashing message becomes "_GO_" to indicate that the combustion control can be carried out.
- Ensure that the CO₂ value corresponds to the value indicated in the "Minimal heat input" column of the following Tables, according to the model and the gas type used. Otherwise, set CO₂ percentage value using the offset adjustment screw.
- Press the key on the user interface to activate the chimney sweep function at maximum power.
- The display shows the letters "CS.HI" (chimney sweep high power), alternating once again with the flashing message "UAIt" (wait) which indicates that the machine is not yet ready for the reading.
- After a short while, the flashing message becomes "_GO_" again to indicate that the combustion control at maximum power can be carried out.
- Ensure that the CO₂ value corresponds to the value indicated in the "Nominal heat input" column of the following Tables, according to the model and the gas type used.

If the check is successful:

- Press the key on the user interface again for 5 seconds to deactivate the chimney sweep function and complete the procedure.
- Screw the cap back over the offset adjustment screw (C) of

the gas valve.

16. Close the thermoformed door.

If the check is not successful:

17. Repeat the checking procedure, at the minimum heat input or at the maximum heat input, until CO₂ values corresponding to those indicated in the following Tables are achieved, according to the model and the type of gas used.

18. Repeat steps 14 to 16 to complete the procedure.

Figure 5.2 Gas valve

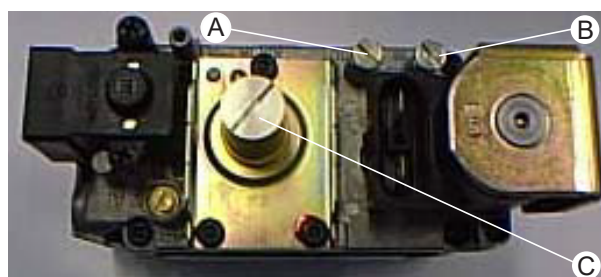

- A Offset pressure intake
- B Gas mains pressure intake
- C Offset adjustment screw

Table 5.7 Next-G 75 gas valve setting table

Gas	Gas network pressure	Screw pre-adjustment	CO ₂ percentage in flue gases	
		Offset	Minimal heat input	Nominal heat input
Type	mbar	turns ↻	%	%
G20	See Table 4.1 p. 4	-6	8,5	8,7
G25		-6	8,1	8,8
G25.1		-6	9,0	9,8
G25.3		-6	8,0	8,7
G27		-6	8,2	9,0
G2.350 (1)		- (1)	- (1)	- (1)
G30		-6	9,8	10,4
G31		-6	9,7	10,2
LPG		-6	9,6	10,1

¹ The gas unit heater cannot operate with this type of gas. A tolerance of ±0,3% is applied to all values of CO₂ percentage in fumes.

Table 5.8 Next-G 90 gas valve setting table

Gas	Gas network pressure	Screw pre-adjustment	CO ₂ percentage in flue gases	
		Offset	Minimal heat input	Nominal heat input
Type	mbar	turns 	%	%
G20	See Table 4.1 p. 4	-6	8,5	9,0
G25		-6	8,1	9,3
G25.1		-6	9,3	10,4
G25.3		-6	8,2	9,3
G27		-6	8,2	9,0
G2.350 (1)		- (1)	- (1)	- (1)
G30		-6	10,2	10,7
G31		-6	9,6	10,5
LPG		-6	9,8	10,5

¹ The gas unit heater cannot operate with this type of gas.
A tolerance of ±0,3% is applied to all values of CO₂ percentage in fumes.