



Installation, use and maintenance manual

Next-R

Gas unit heaters for use in industrial and commercial installations

Powered by natural gas/LPG



DISPOSAL

The appliance and all its accessories must be disposed of separately in accordance with the regulations in force.



Use of the WEEE symbol (Waste Electrical and Electronic Equipment) indicates that this product cannot be disposed of as household waste. Proper disposal of this product helps to prevent potential negative consequences for the environment and human health.

Revision: N

Code: D-LBR851

This Installation, use and maintenance manual has been drawn up and printed by Robur S.p.A.; whole or partial reproduction of this Installation, use and maintenance manual is prohibited.

The original is filed at Robur S.p.A.

Any use of this Installation, use and maintenance manual other than for personal consultation must be previously authorised by Robur S.p.A.

The rights of those who have legitimately filed the registered trademarks contained within this publication are not affected.

With the aim of continuously improving the quality of its products, Robur S.p.A. reserves the right to modify the data and contents of this Installation, use and maintenance manual without prior notice.

TABLE OF CONTENTS

I Introduction.....4	3.2 Fuel gas supply 28
I.1 Recipients4	3.3 Combustion products exhaust 29
I.2 Control device4	3.4 Opening the grille louveres 33
II Symbols and definitions4	3.5 Air ducting 34
II.1 Key to symbols4	4 Electrical installer34
II.2 Terms and definitions4	4.1 Warnings 34
III Warnings4	4.2 Electrical systems 34
III.1 General and safety warnings4	4.3 Electrical power supply 34
III.2 Compliance5	4.4 Control system 35
III.3 Exclusions of liability and warranty6	5 First start-up41
1 Features and technical data.....7	5.1 Preliminary checks 41
1.1 Features7	5.2 Combustion parameters check 41
1.2 Dimensions8	5.3 Gas changeover 45
1.3 Components 18	6 Normal operation45
1.4 Electrical wiring diagram 20	6.1 Warnings 45
1.5 Operation mode 22	6.2 Switch on and off 45
1.6 Controls 22	6.3 Restarting a locked-out unit 46
1.7 Technical data 23	6.4 Efficiency 46
2 Transport and positioning25	7 Maintenance47
2.1 Warnings 25	7.1 Warnings 47
2.2 Handling and lifting 25	7.2 Scheduled routine maintenance 47
2.3 Appliance positioning 25	7.3 Resetting the temperature limit thermostat 47
2.4 Minimum clearance distances 25	7.4 Periods of inactivity 47
2.5 Support bracket 27	8 Appendices49
3 Heating engineer28	8.1 Product fiche 49
3.1 Warnings 28	EU Declaration of conformity (DoC)55

I INTRODUCTION



Installation, use and maintenance manual

This Manual is an integral part of the Next-R appliance and must be handed to the end user together with the appliance.

I.1 RECIPIENTS

This Manual is intended for:

- ▶ End user, for appropriate and safe use of the appliance.
- ▶ Qualified installer, for correct appliance installation.
- ▶ Planner, for specific information on the appliance.

I.2 CONTROL DEVICE

In order to work, the Next-R unit requires a control device to be connected by the installer (see Paragraph 1.6 p. 22).

II SYMBOLS AND DEFINITIONS

II.1 KEY TO SYMBOLS



DANGER



WARNING



NOTE



PROCEDURE



REFERENCE (to other document)

II.2 TERMS AND DEFINITIONS

Appliance / Unit = equivalent terms, both used to refer to the gas unit heater.

TAC = Robur authorized Technical Assistance Centre.

OCDS012 1-key basic control = control device that signals the flame lock-out and allows its resetting.

OCTR000 2-key basic control = control device that signals the flame lock-out and allows its resetting and also allows selecting winter operation (space heating) or summer operation (ventilation).

External request = generic control device (e.g. thermostat, timer or any other system) equipped with a voltage-free NO contact and used as control to start/stop the unit.

OCDS008 digital chronothermostat = device that integrates the functions of room temperature control and remote control of one or more Next-R gas unit heaters, when connected to the OTRG005 thermoregulator.

First start-up = appliance commissioning operation which may only and exclusively be carried out by a TAC.

OSWR000 Genius software for remote management = software that allows, through the OTRG005 thermoregulators, to centralize the management of up to 100 Next-R gas unit heaters.

OTRG005 thermoregulator = control device that allows to manage settings and operation of one Next-R gas unit heater.

III WARNINGS

III.1 GENERAL AND SAFETY WARNINGS



Installer's qualifications

Installation must exclusively be performed by a qualified firm and by skilled personnel, with specific knowledge on heating, electrical systems and gas appliances, in compliance with the laws in force in the Country of installation.



Declaration of conformity

Upon completing installation, the installing firm shall issue to the owner/client the appliance's workmanlike conformity declaration, according to national/local regulations in force and the manufacturer's instructions/provisions.



Misuse

The appliance must only be used for the purposes for which it has been designed. Any other use is deemed hazardous. Incorrect use may affect operation, duration

and safety of the appliance. Adhere to the manufacturer's instructions.



Use of the appliance by children

The appliance can be used by children over 8 years old, and by people with reduced physical, sensory or mental capabilities, or lack of experience or knowledge, only if they are under surveillance or after they have received instructions regarding safe use of the appliance and understanding the dangers inherent in it. Children should not play with the appliance.



Hazardous situations

- Do not start the appliance in hazardous conditions, such as: gas smell, problems with the electrical/gas system, parts of the appliance under water or damaged, malfunctioning, disabling or bypassing control and safety devices.
- In case of danger, request intervention by qualified personnel.
- In case of danger, switch off the electrical power and gas

supplies only if this can be done in total safety.



Gas component tightness

- Before performing any operation on gas ducting components, close the gas valve.
- Upon completing any procedure, perform the tightness test according to regulations in force.



Gas smell

If you smell gas:

- Do not use electrical devices such as telephones, multimeters or other equipment that may cause sparks next to the appliance.
- Shut off the gas supply by turning the valve off.
- Open immediately doors and windows to create a cross-current of air to ventilate the room.
- Switch off the power supply via the external disconnect switch in the power supply electrical panel.
- Use a telephone away from the appliance to ask for intervention from qualified personnel.



Poisoning

- Ensure the flue gas ducts are tight and compliant with the regulations in force.
- Upon completing any procedure, ensure the tightness of the components.



Moving parts

The appliance contains moving parts.

- Do not remove guards during operation, and in any case prior to disconnecting the power supply.



Burn hazard

The appliance contains very hot parts.

- Do not open the appliance and do not touch internal components before the appliance has cooled down.
- Do not touch the flue gas exhaust before it has cooled down.



Electrocution hazard

- Disconnect the electrical power supply before any operation on appliance components.
- For electrical connections exclusively use compliant components and according to the specifications provided by the manufacturer.
- Ensure the appliance cannot be accidentally switched back on.



Protection devices

Wear appropriate protective equipment when handling the front grille louvres.



Earthing

Electrical safety depends on effective earthing system, correctly connected to the appliance and installed according to the regulations in force.



Air flow

Do not obstruct the fan intake or the warm air outlet.



Distance from combustible or flammable materials

- Do not deposit flammable materials (paper, diluents, paints, etc.) near the appliance.
- Comply with current regulations.



Aggressive substances in the air

The air of the installation site must be free from aggressive substances.



Acid flue gas condensate

Discharge the acid condensate of combustion flue gas in compliance with current exhaust regulations.



Switching the appliance off

Disconnecting the power supply while the appliance is running may cause permanent damage to internal components.

- Except in the event of danger, do not disconnect the power supply to switch off the appliance, but always and exclusively act through the provided control device.



In the event of failure

Operations on internal components and repairs may exclusively be carried out by a TAC, using only original spare parts.

- In the event of failure of the appliance and/or breakage of any component, do not attempt to repair and/or restore and immediately contact the TAC.



Routine maintenance

Proper maintenance assures the efficiency and good operation of the appliance over time.

- Maintenance must be performed according to the manufacturer's instructions (see Chapter 7 p. 47) and in compliance with current regulations.
- Appliance maintenance and repairs may only be entrusted to firms legally authorised to work on gas appliances and systems.
- Enter into a maintenance contract with an authorised specialised firm for routine maintenance and for servicing in case of need.
- Use only original parts.



Keep the Manual

This Installation, use and maintenance manual must always accompany the appliance and must be handed to the new owner or installer in the event of sale or removal.

III.2 COMPLIANCE

EU directives and standards

The Next-R series gas unit heaters are certified in accordance with European regulation GAR 2016/426/EU and meet the essential requirements of the following Directives:

- ▶ 2016/426/EU "Gas Appliances Regulation" as amended and added.
- ▶ 2014/30/EC "Electromagnetic Compatibility Directive" as amended and added.
- ▶ 2014/35/EC "Low Voltage Directive" as amended and added.

- ▶ 2281/2016/EU "Ecodesign requirements for air heating products" as amended and added.

Furthermore, they comply with the requirements of the following standards:

- ▶ EN 17082 Domestic and non-domestic gas-fired forced convection air heaters for space heating not exceeding a net heat input of 300 kW.

Other applicable provisions and standards

The design, installation, operation and maintenance of the systems shall be carried out in compliance with current applicable regulations, depending on the Country and location, and in accordance with the manufacturer's instructions. In particular, regulations regarding the following shall be complied with:

- ▶ Gas systems and equipment.
- ▶ Electrical systems and equipment.
- ▶ Heating systems.
- ▶ Environmental protection and combustion products exhaust.
- ▶ Fire safety and prevention.
- ▶ Any other applicable law, standard and regulation.

III.3 EXCLUSIONS OF LIABILITY AND WARRANTY



Any contractual or extra-contractual liability of the man-

ufacturer for any damage caused by incorrect installation and/or improper use and/or failure to comply with regulations and with the manufacturer's directions/instructions shall be disclaimed.



In particular, the warranty on the appliance may be rendered void by the following conditions:

- Incorrect installation.
- Misuse.
- Failure to comply with the manufacturer's indications on installation, use and maintenance.
- Alteration or modification of the product or any part thereof.
- Extreme operational conditions or however outside of the operational ranges set forth by the manufacturer.
- Damages caused by external agents such as salts, chlorine, sulphur or other chemical substances present in the air of the installation site.
- Abnormal actions transmitted to the appliance by the plant or installation (mechanical stresses, pressure, vibrations, thermal expansion, electrical surges...).
- Accidental damages or due to force majeure.

1 FEATURES AND TECHNICAL DATA

1.1 FEATURES

1.1.1 Available range

Next-R gas unit heaters are available in three versions:

- ▶ with horizontal flow, with axial fan (Next-R series)
- ▶ with horizontal flow, ductables, with centrifugal fan (Next-R C series)
- ▶ with vertical downflow (Next-R V series)



Choosing the correct flow direction

Due to characteristics and positioning of internal components, Next-R V vertical downflow gas unit heaters cannot be used for horizontal flow operation, and vice versa, horizontal flow gas unit heaters cannot under any circumstances be used for vertical downflow operation.

The R15 and R20 gas unit heaters have the possibility, when combined with the adjustable support bracket OSTF020 (available as an optional), to be used with horizontal, oblique or vertical throw.

1.1.2 Operation

The Next-R series gas unit heater is an independent heating appliance with airtight combustion circuit and forced air draft. It has been designed to be installed inside the room to be heated.

The combustion circuit is room sealed and meets the requirements for type C appliances: combustion air supply and flue gas exhaust discharge take place outdoors and are ensured by the functioning of a blower inserted in the combustion circuit.

The appliance is also approved for type B for installations where it is allowed to take the combustion air directly from the installation room.

The operation of the gas unit heater is controlled by a control device (not supplied).

The gas unit heater can operate on two heat output levels, with constant fan speed.

A blower upline of the burner mixes the air and gas and expels the combustion fumes.

Products of gas combustion (natural gas or LPG) flow internally through the heat exchangers, which are invested externally by the air current produced by the fan, delivering warm air flow into

the room.

The fan operates automatically only when it receives the enabling signal, depending on the model, from the fan thermostat or by the electronic board timer, i.e. with hot heat exchangers, in order to avoid the introduction of cold air into the room, and it will switch off with cold exchangers.

The air flow direction is adjustable vertically by means of the revolving louvres of the grille.

If heat exchangers overheat due to malfunction, a temperature limit thermostat cuts off the supply to the gas valve, thus interrupting fuel flow and turning off the burner.

In the event of obstructions in the intake or exhaust duct, or in the event of malfunction of the blower, the gas valve stops, thus also interrupting the flow of fuel to the burner.

In summer it is possible to operate the fan only in order to provide a pleasant air flow within the room.

1.1.3 Mechanical components

- ▶ Stainless steel multigas premix burner.
- ▶ High head blower.
- ▶ Control board for brushless motor of the blower.
- ▶ Cylindrical stainless steel combustion chamber.
- ▶ Corrugated stainless steel heat exchangers with very large exchange surface (R15, R20 models).
- ▶ Robur patented heat exchangers, made out of a special aluminium die-cast alloy, with horizontal finning on the air side and vertical finning on the flue gas exhaust side, with a very high heat exchange capacity (R30, R40, R50, R60, R80 models).
- ▶ External steel panelling with epoxy powder enamel finish.
- ▶ Axial fan(s) with high flow rate.
- ▶ Centrifugal fan (for the Next-R C series).

1.1.4 Control and safety devices

- ▶ 100 °C limit thermostat with manual reset against heat exchangers overheating.
- ▶ Differential pressure switch for controlling the correct operation of the blower (all models except R15, R20).
- ▶ Fan thermostat (for R30, R40, R50, R60, R80 models).
- ▶ Ventilation timer (for R15, R20 models).
- ▶ Gas solenoid valve.
- ▶ Controller for ignition, adjustment and flame control.

1.2 DIMENSIONS

1.2.1 Axial gas unit heaters

1.2.1.1 R15/R20

Figure 1.1 Unit dimensions

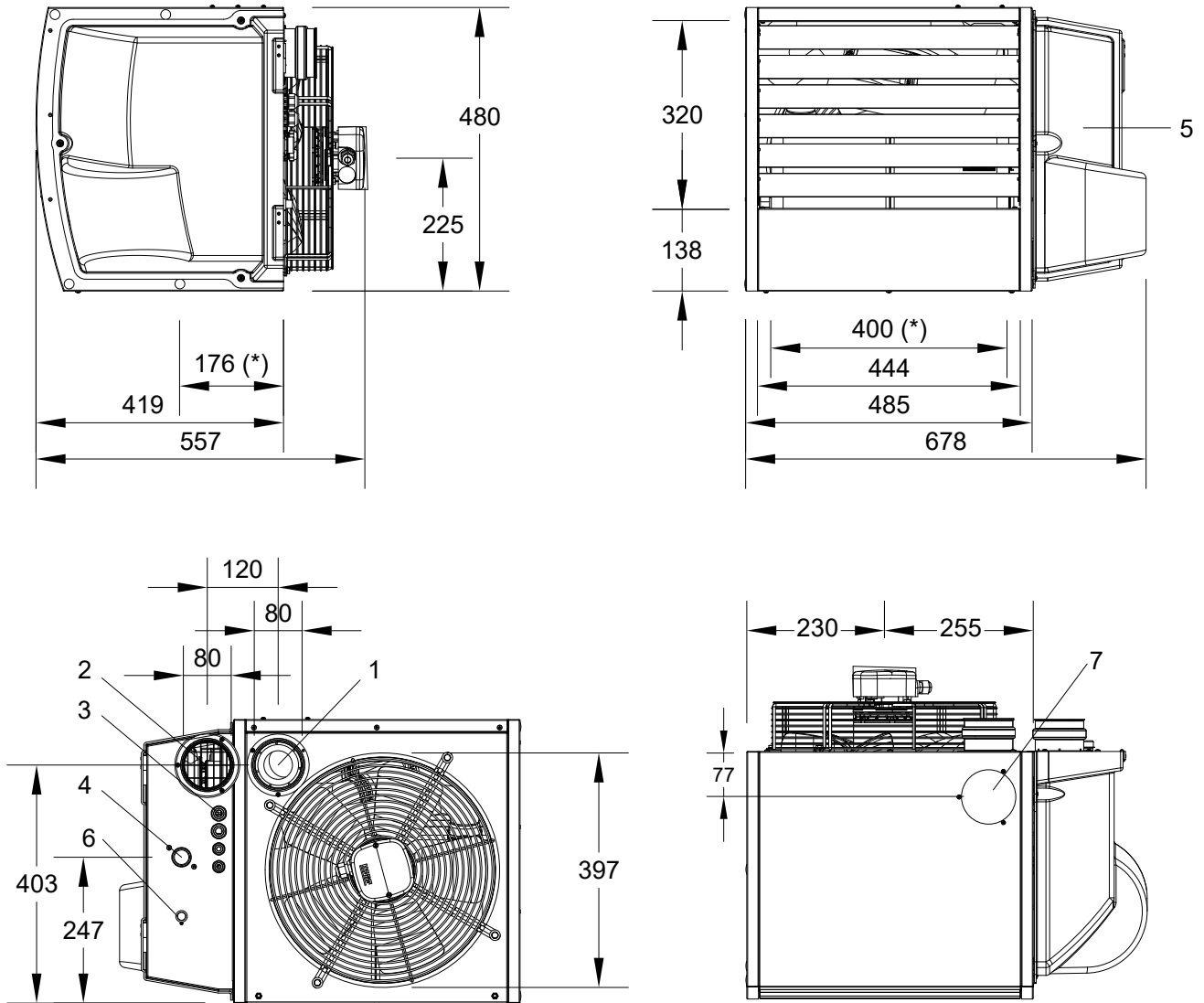

- 1 Flue gas exhaust
- 2 Combustion air inlet
- 3 Power supply cables input
- 4 Gas connection 3/4" M

- 5 Thermoformed door
- 6 Limit thermostat reset button
- 7 Flue gas exhaust blind cover, alternative to the rear one (1)
- (*) Holes for fixing to the support bracket

1.2.1.2 R30

Figure 1.2 Unit dimensions

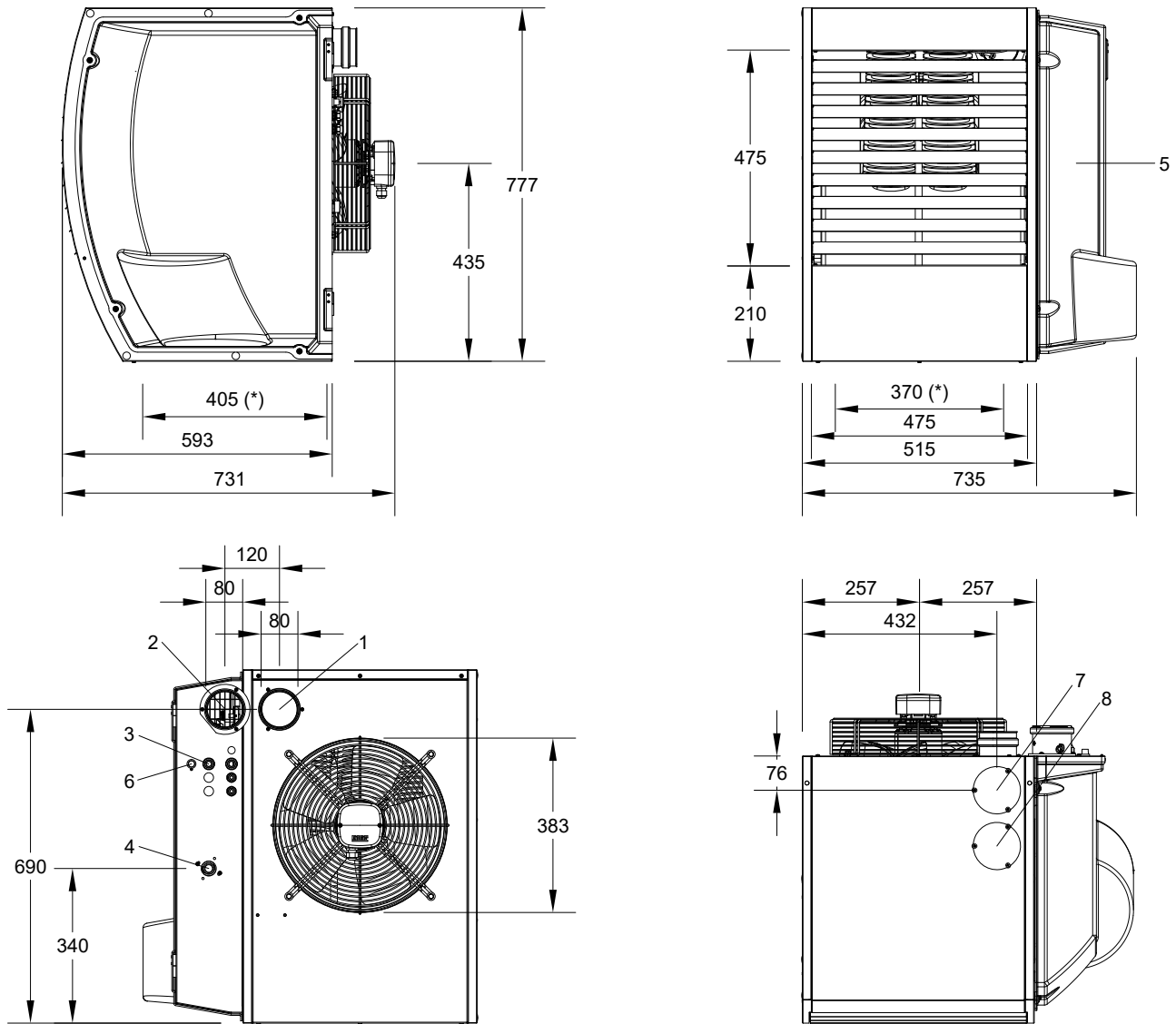

- 1 Flue gas exhaust
- 2 Combustion air inlet
- 3 Power supply cables input
- 4 Gas connection 3/4" M
- 5 Thermoformed door
- 6 Limit thermostat reset button
- 7 Flue gas exhaust blind cover, alternative to the rear one (1)
- 8 Blind cover for access to the fan thermostat
- (*) Holes for fixing to the support bracket

1.2.1.3 R40

Figure 1.3 Unit dimensions

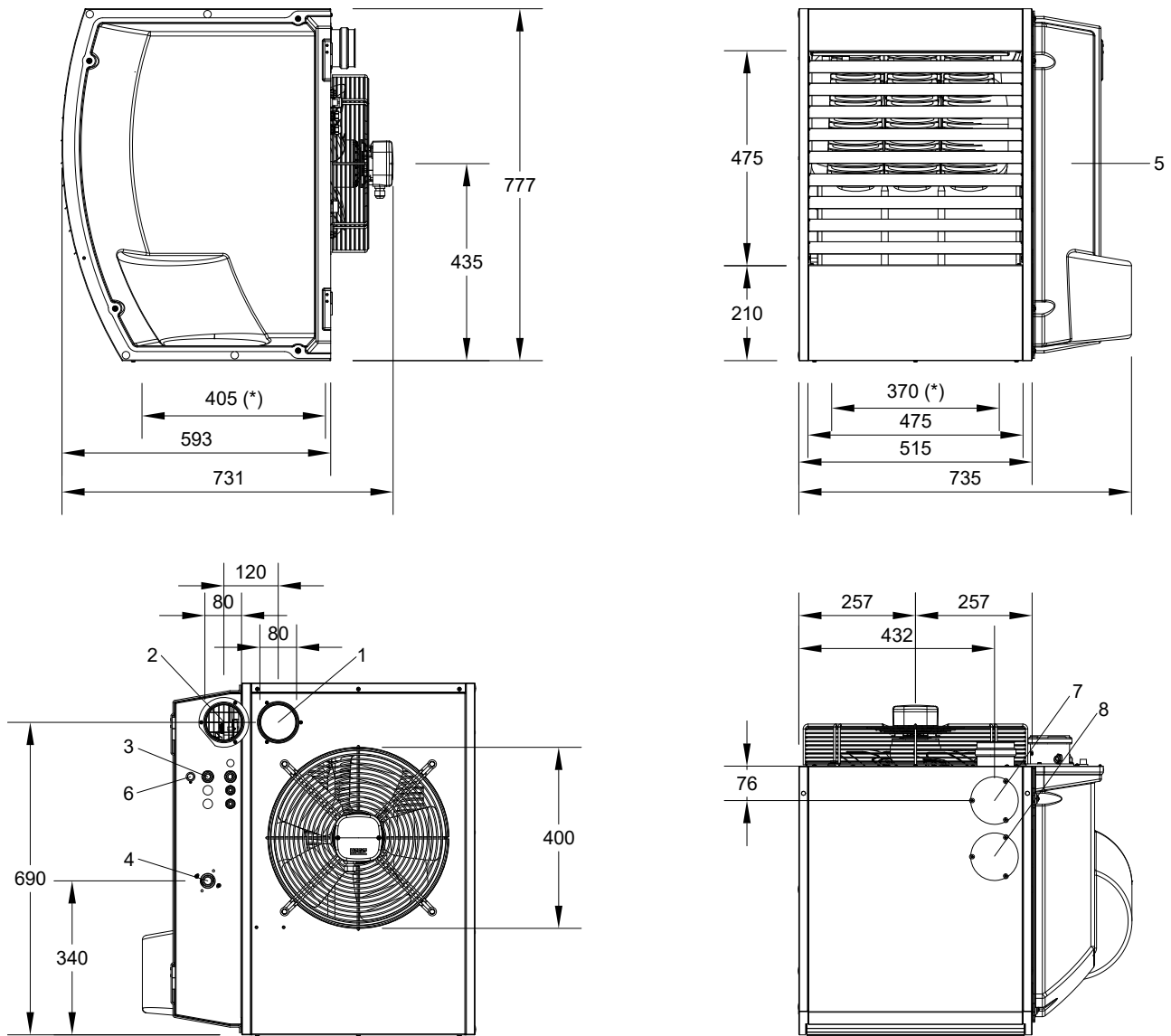

- 1 Flue gas exhaust
- 2 Combustion air inlet
- 3 Power supply cables input
- 4 Gas connection 3/4" M
- 5 Thermoformed door

- 6 Limit thermostat reset button
- 7 Flue gas exhaust blind cover, alternative to the rear one (1)
- 8 Blind cover for access to the fan thermostat
- (*) Holes for fixing to the support bracket

1.2.1.4 R50

Figure 1.4 Unit dimensions

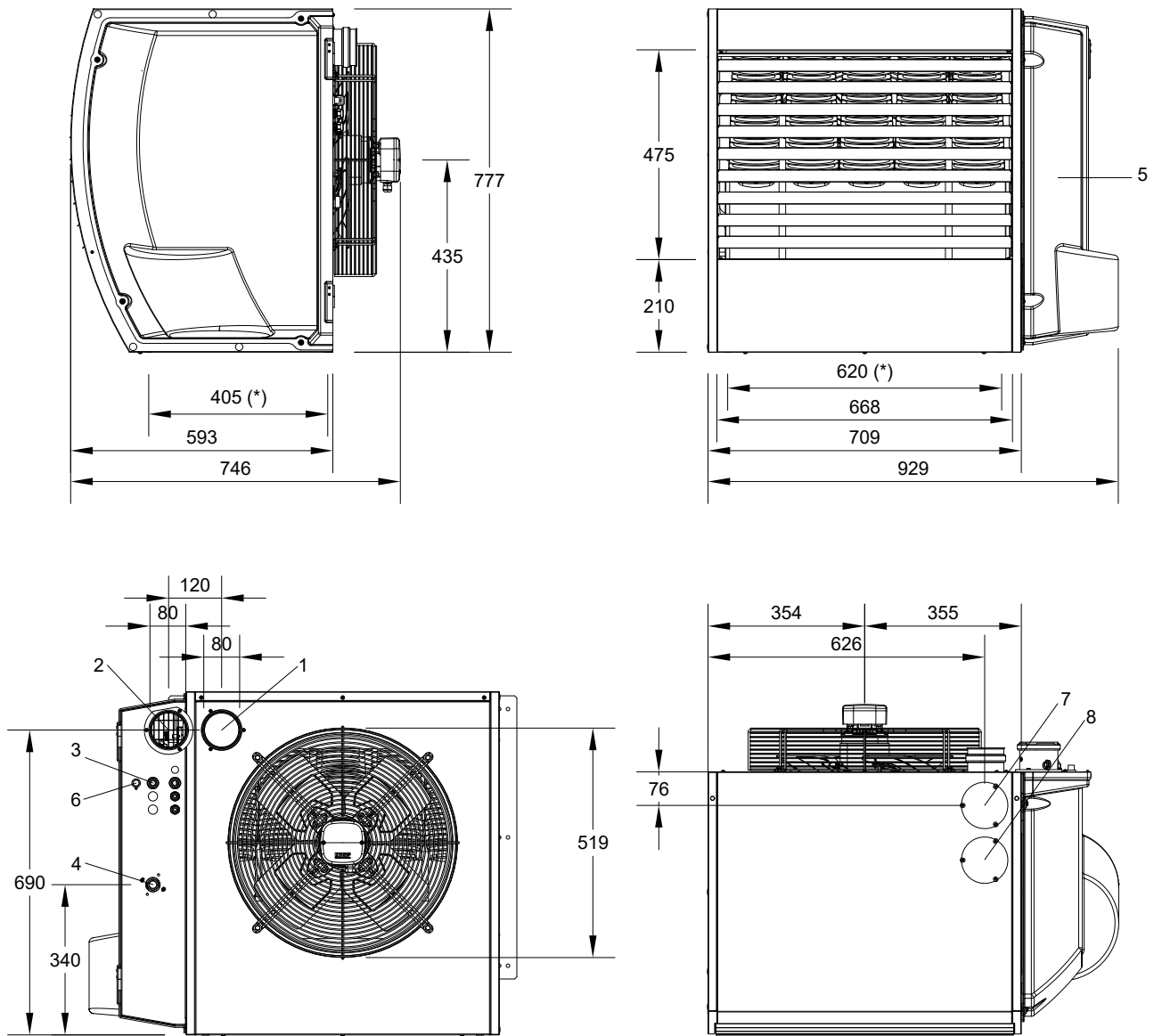

- 1 Flue gas exhaust
- 2 Combustion air inlet
- 3 Power supply cables input
- 4 Gas connection 3/4" M
- 5 Thermoformed door
- 6 Limit thermostat reset button
- 7 Flue gas exhaust blind cover, alternative to the rear one (1)
- 8 Blind cover for access to the fan thermostat
- (*) Holes for fixing to the support bracket

1.2.1.5 R60

Figure 1.5 Unit dimensions

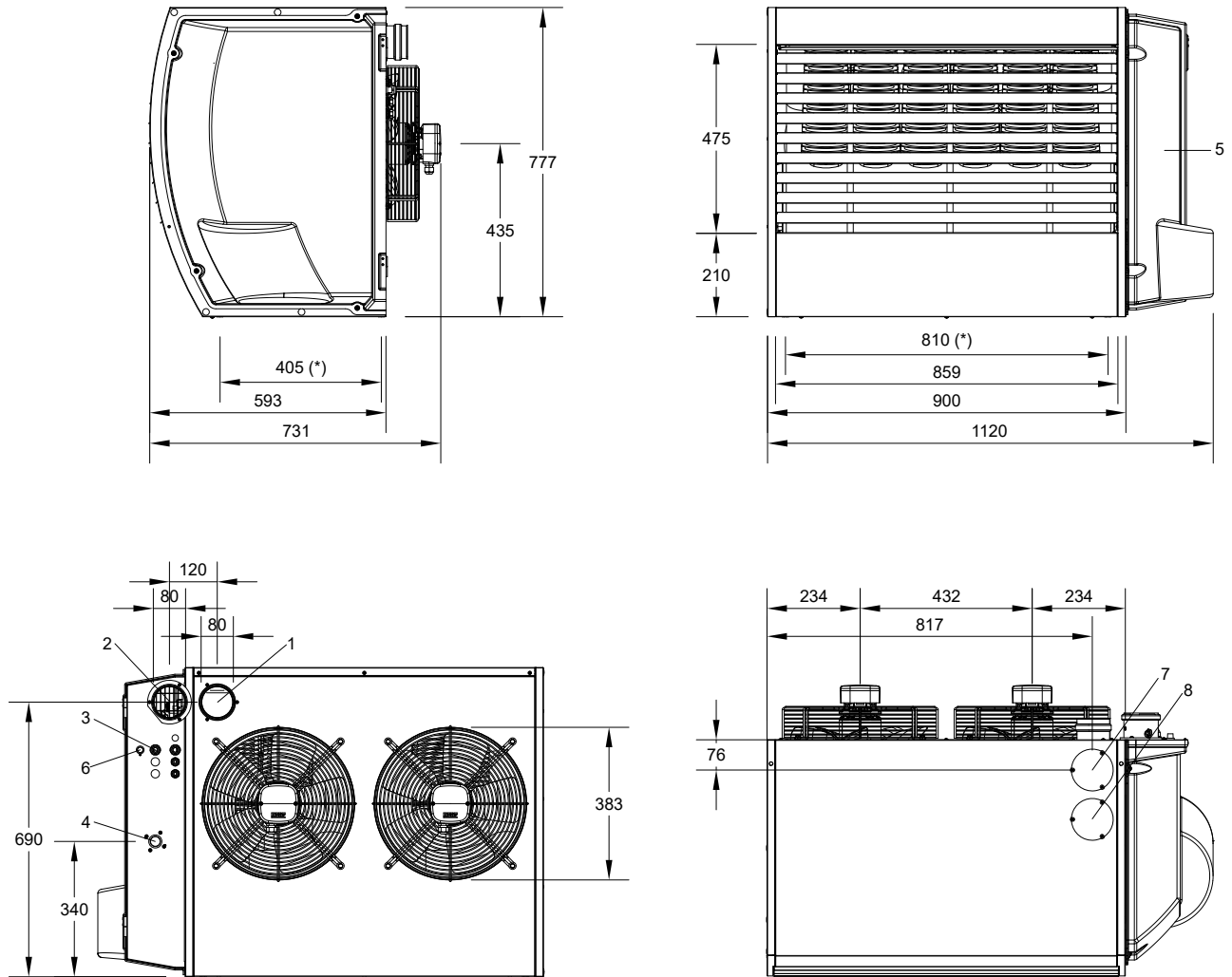

- 1 Flue gas exhaust
- 2 Combustion air inlet
- 3 Power supply cables input
- 4 Gas connection 3/4" F
- 5 Thermoformed door
- 6 Limit thermostat reset button
- 7 Flue gas exhaust blind cover, alternative to the rear one (1)
- 8 Blind cover for access to the fan thermostat
- (*) Holes for fixing to the support bracket

1.2.1.6 R80

Figure 1.6 Unit dimensions

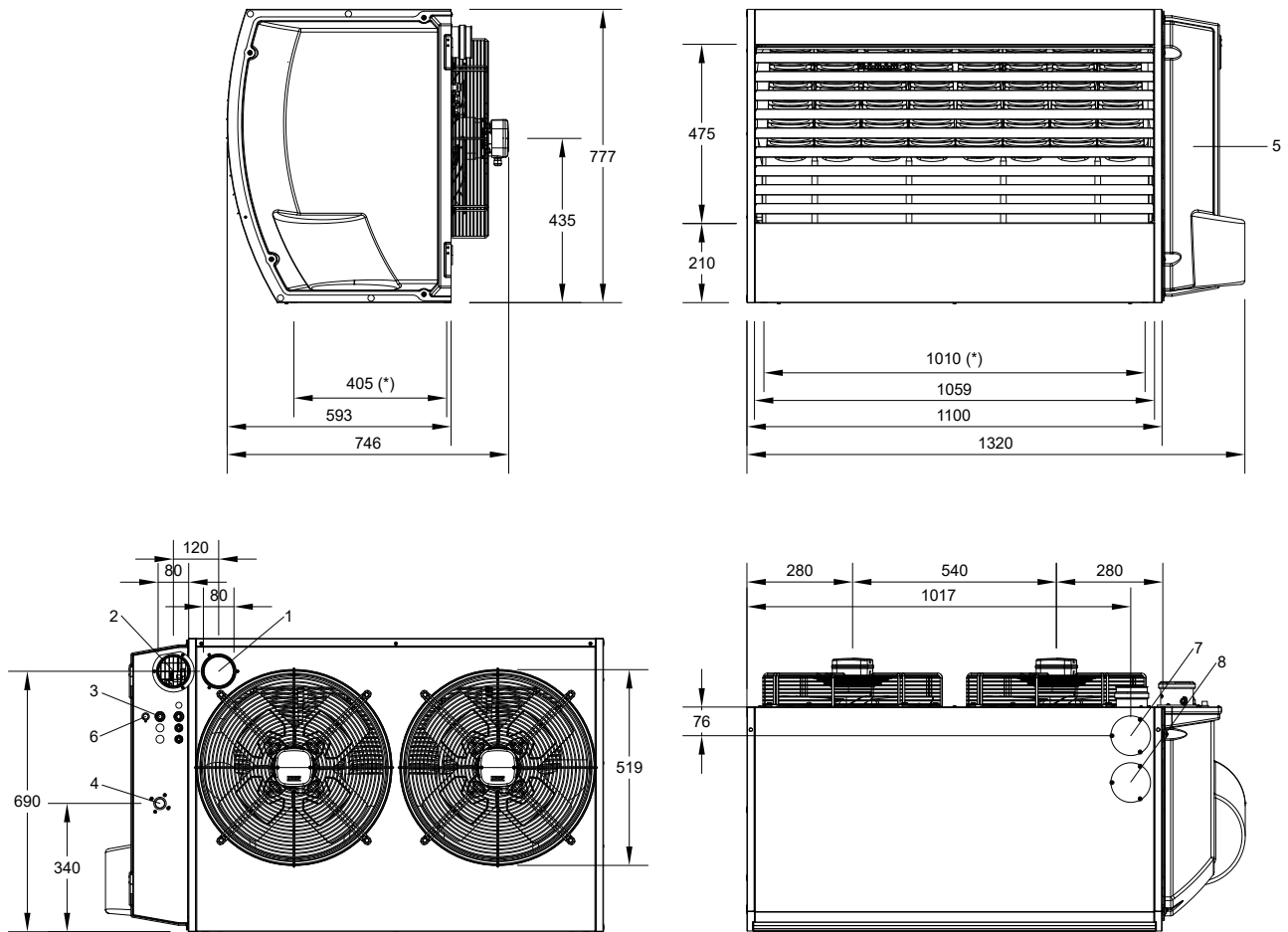

- 1 Flue gas exhaust
- 2 Combustion air inlet
- 3 Power supply cables input
- 4 Gas connection 3/4" F
- 5 Thermoformed door
- 6 Limit thermostat reset button
- 7 Flue gas exhaust blind cover, alternative to the rear one (1)
- 8 Blind cover for access to the fan thermostat
- (*) Holes for fixing to the support bracket

1.2.2 Centrifugal gas unit heaters

1.2.2.1 R30 C

Figure 1.7 Unit dimensions

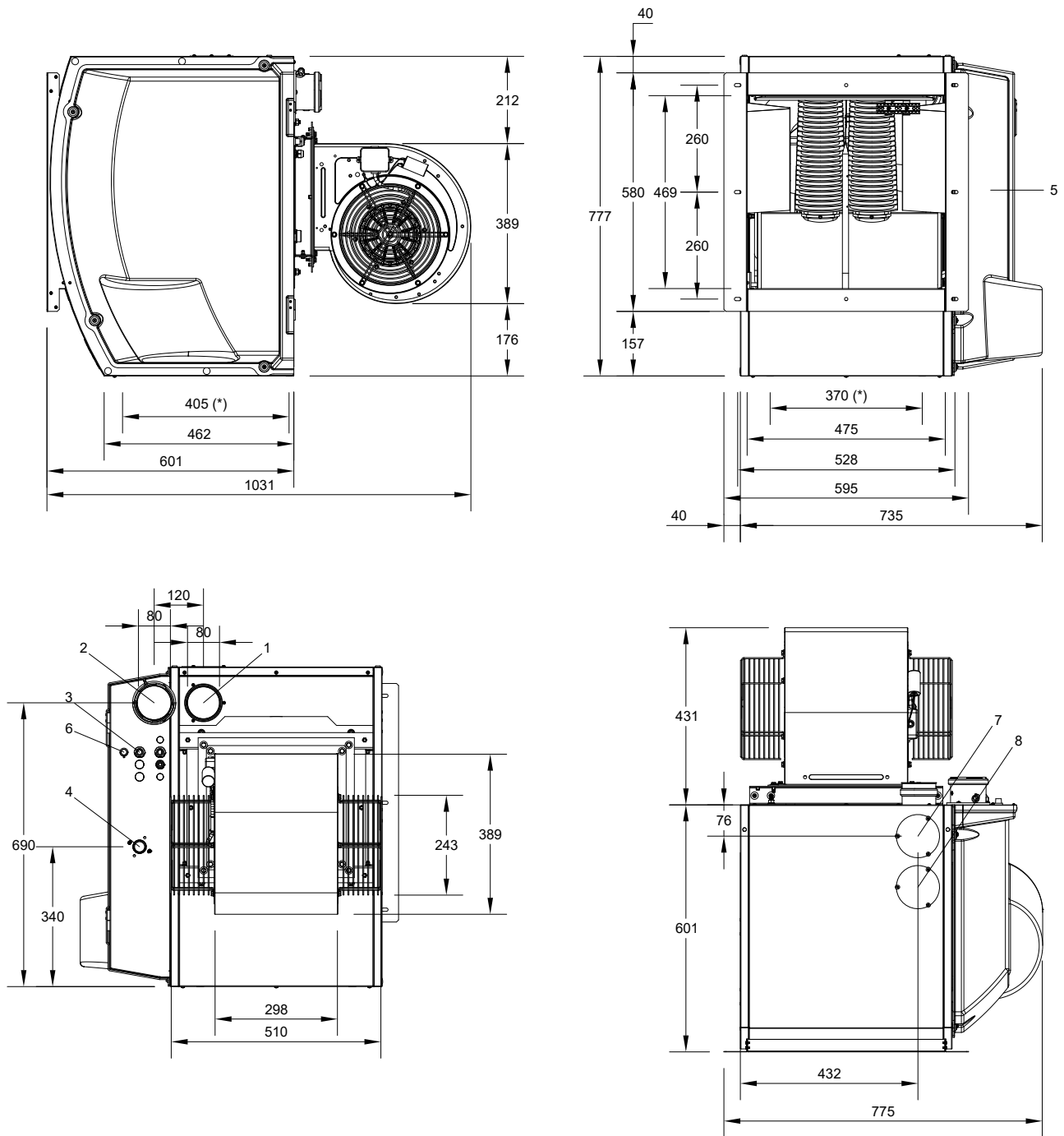

- 1 Flue gas exhaust
- 2 Combustion air inlet
- 3 Power supply cables input
- 4 Gas connection 3/4" M
- 5 Thermoformed door
- 6 Limit thermostat reset button
- 7 Flue gas exhaust blind cover, alternative to the rear one (1)
- 8 Blind cover for access to the fan thermostat
- (*) Holes for fixing to the support bracket

1.2.2.2 R40 C

Figure 1.8 Unit dimensions

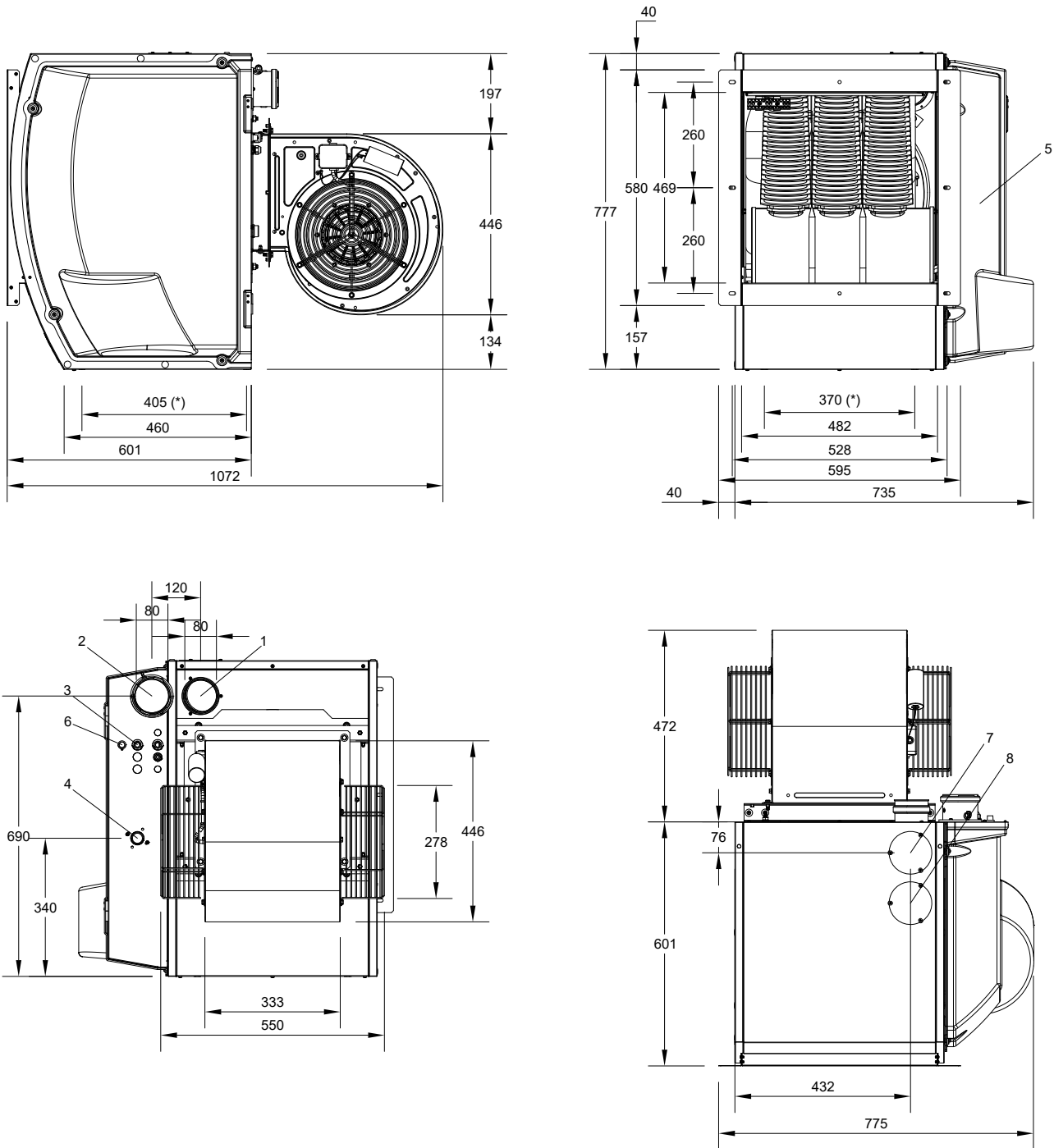

- 1 Flue gas exhaust
- 2 Combustion air inlet
- 3 Power supply cables input
- 4 Gas connection 3/4" M
- 5 Thermoformed door
- 6 Limit thermostat reset button
- 7 Flue gas exhaust blind cover, alternative to the rear one (1)
- 8 Blind cover for access to the fan thermostat
- (*) Holes for fixing to the support bracket

1.2.2.3 R50 C

Figure 1.9 Unit dimensions

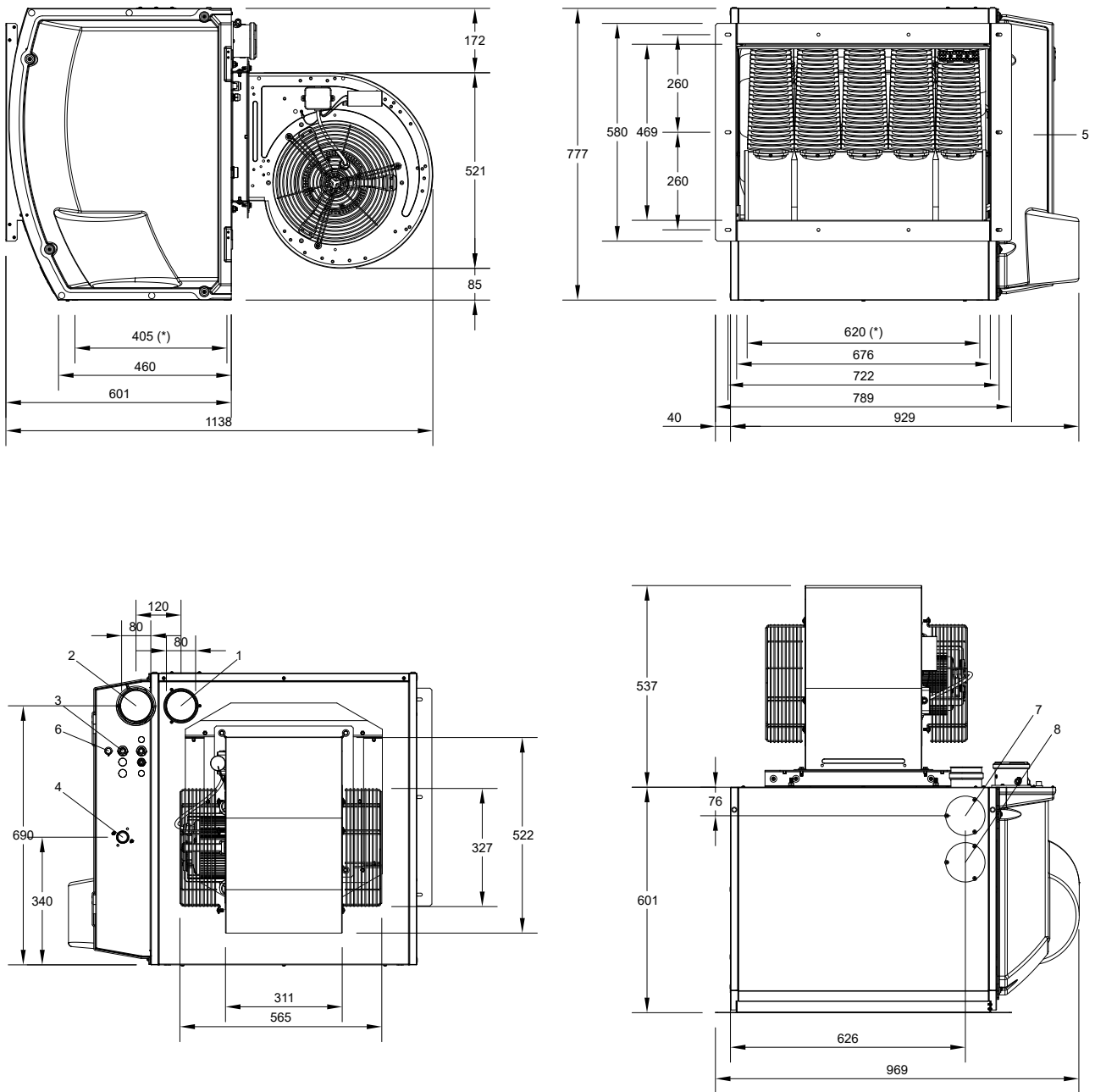

- 1 Flue gas exhaust
- 2 Combustion air inlet
- 3 Power supply cables input
- 4 Gas connection 3/4" M
- 5 Thermoformed door
- 6 Limit thermostat reset button
- 7 Flue gas exhaust blind cover, alternative to the rear one (1)
- 8 Blind cover for access to the fan thermostat
- (*) Holes for fixing to the support bracket

1.2.2.4 R80 C

Figure 1.10 Unit dimensions

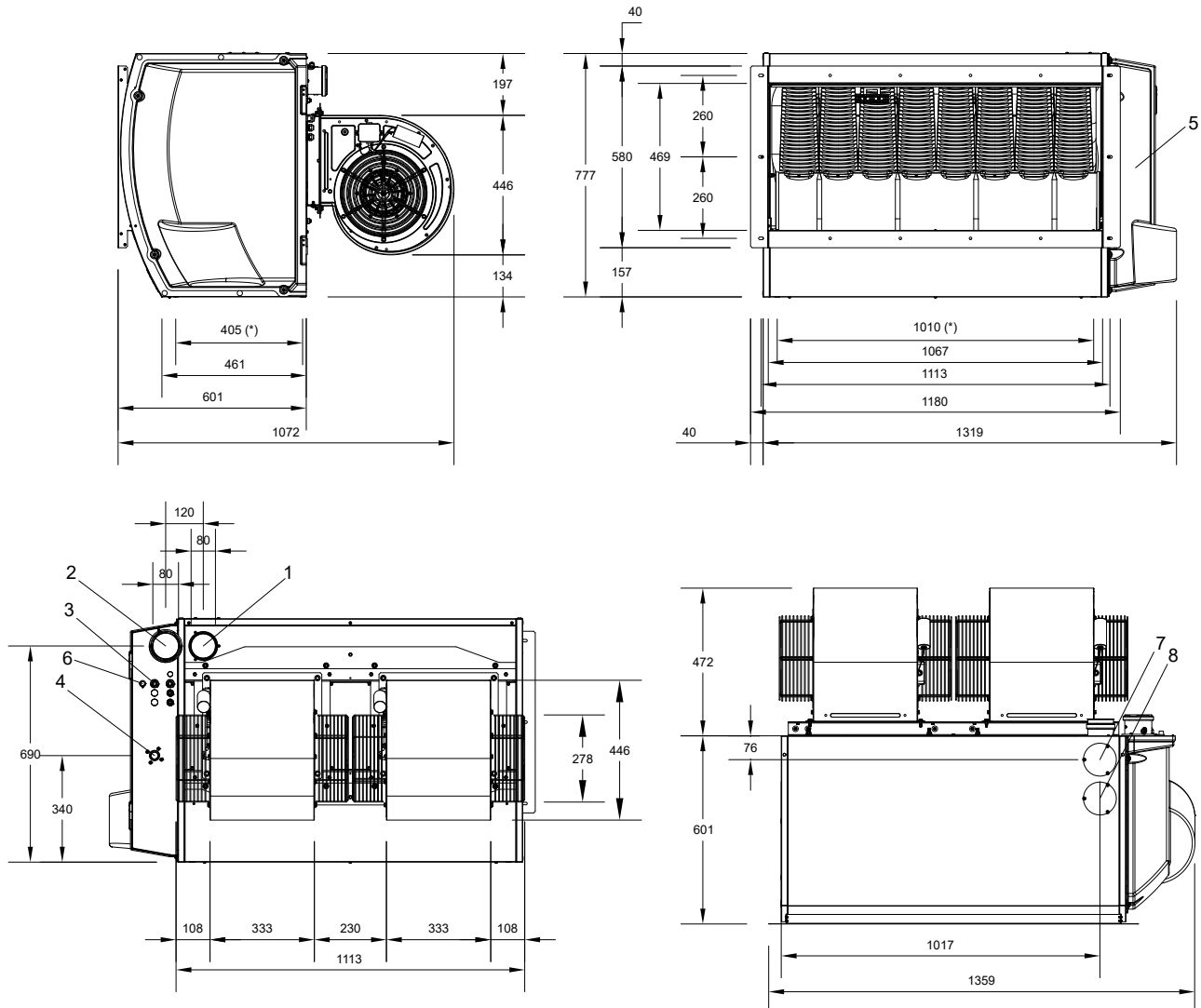

- 1 Flue gas exhaust
- 2 Combustion air inlet
- 3 Power supply cables input
- 4 Gas connection 3/4" F
- 5 Thermoformed door

- 6 Limit thermostat reset button
- 7 Flue gas exhaust blind cover, alternative to the rear one (1)
- 8 Blind cover for access to the fan thermostat
- (*) Holes for fixing to the support bracket

1.2.3 Vertical downflow gas unit heaters

The dimensions of the vertical downflow gas unit heaters are identical to those of the corresponding axial models (Paragraph 1.2.1 p. 8).

Figure 1.11 p. 18 below details the centre distances between

the vertical suspension brackets for the different models of vertical downflow gas unit heaters.

The R15 and R20 gas unit heaters are not equipped with vertical suspension brackets, as the installation with vertical downflow is carried out by means of the revolving bracket OSTF020 (available as an optional, Paragraph 2.5.4 p. 27).

Figure 1.11 Position of vertical downflow gas unit heaters brackets

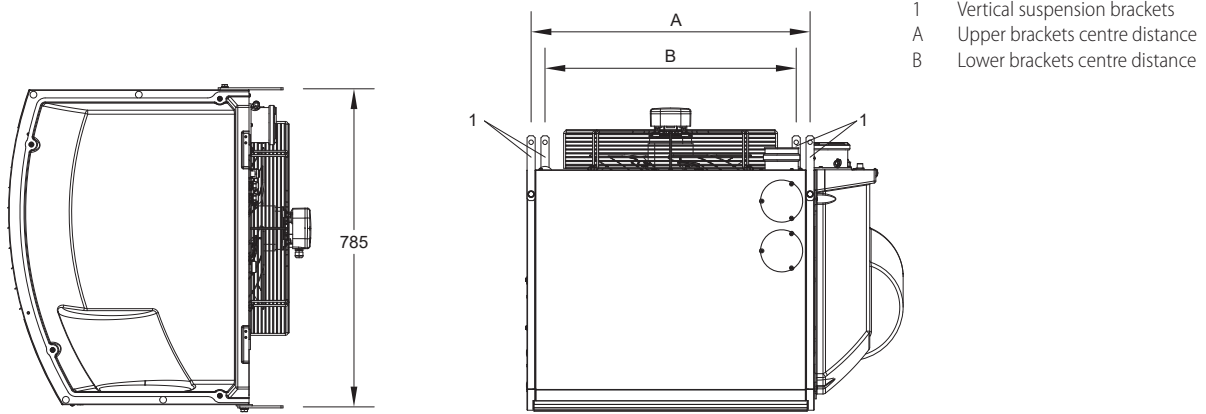

Table 1.1 Centre distance of the vertical suspension brackets

Model	A	B
R30 V	494	370
R40 V	494	370
R50 V	688	620

1.3 COMPONENTS

1.3.1 R15/R20

Figure 1.12 Internal components

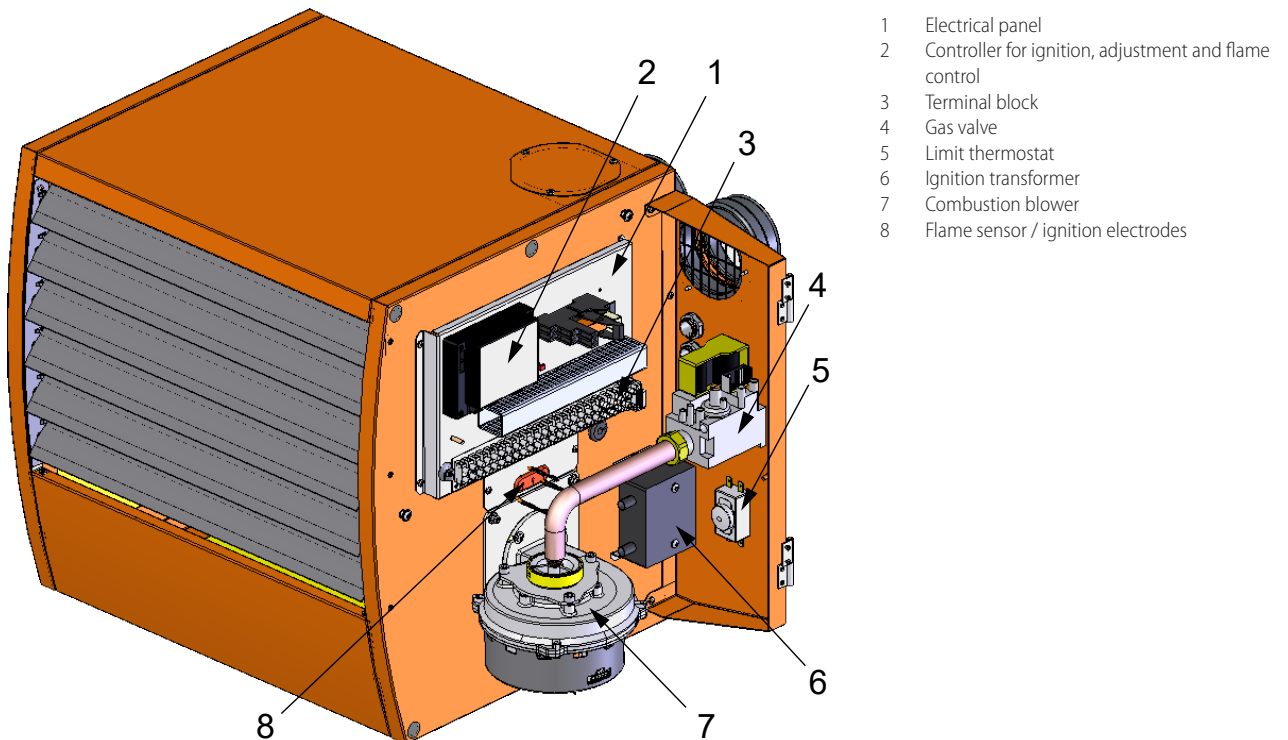

1.3.2 R30/R40/R50/R60/R80

Figure 1.13 Internal components

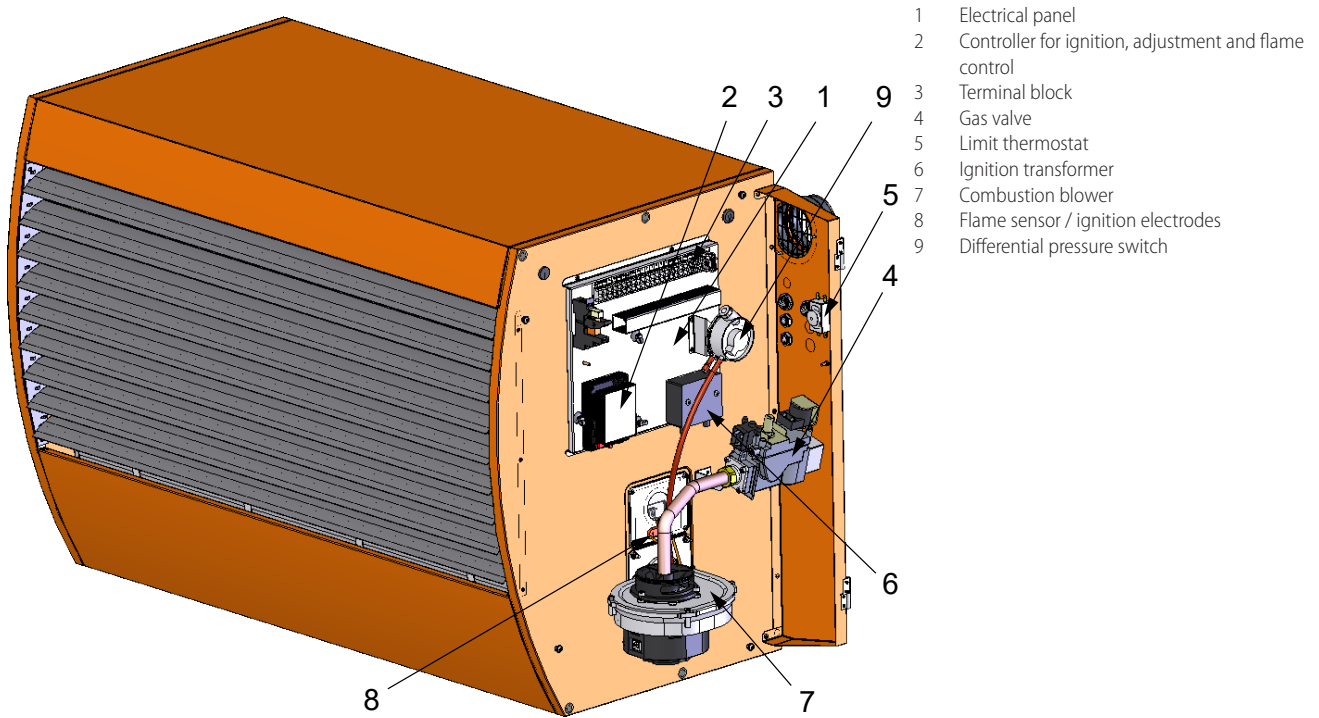

1.4 ELECTRICAL WIRING DIAGRAM

1.4.1 R15/R20

Figure 1.14 Electrical wiring diagram

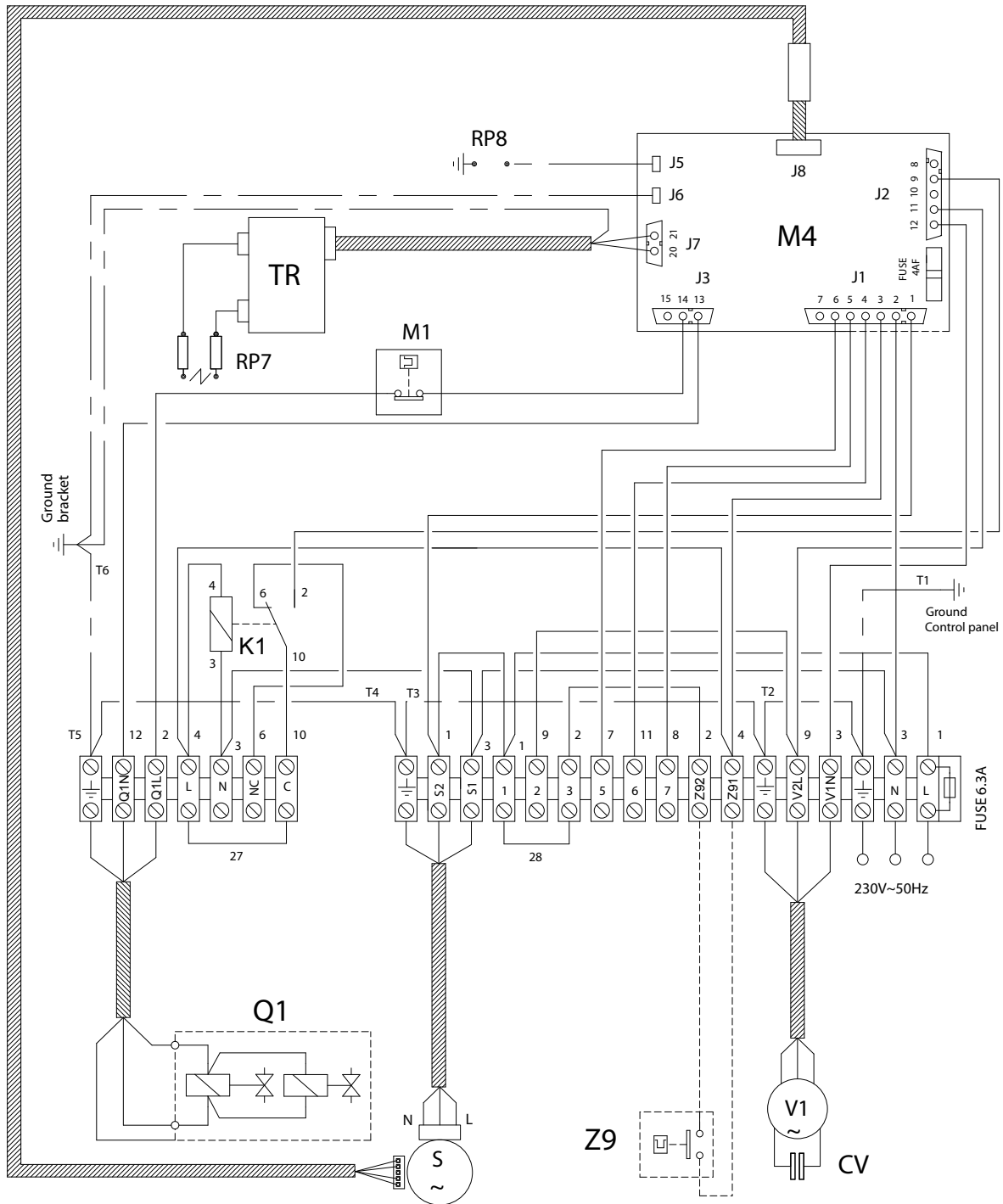

- | | | | |
|-----|---|----|---------------------------------|
| CV | Fan condenser | S | Blower |
| K1 | Internal modulation relay | TR | Ignition transformer |
| M1 | Limit thermostat | V1 | Fan |
| M4 | Controller for ignition, adjustment and flame control | Z9 | External request (not supplied) |
| Q1 | Gas valve | 27 | Power level control contact |
| RP7 | Ignition electrodes | 28 | Winter mode activation contact |
| RP8 | Flame sensor | | |

1.4.2 R30/R40/R50/R60/R80

Figure 1.15 Electrical wiring diagram

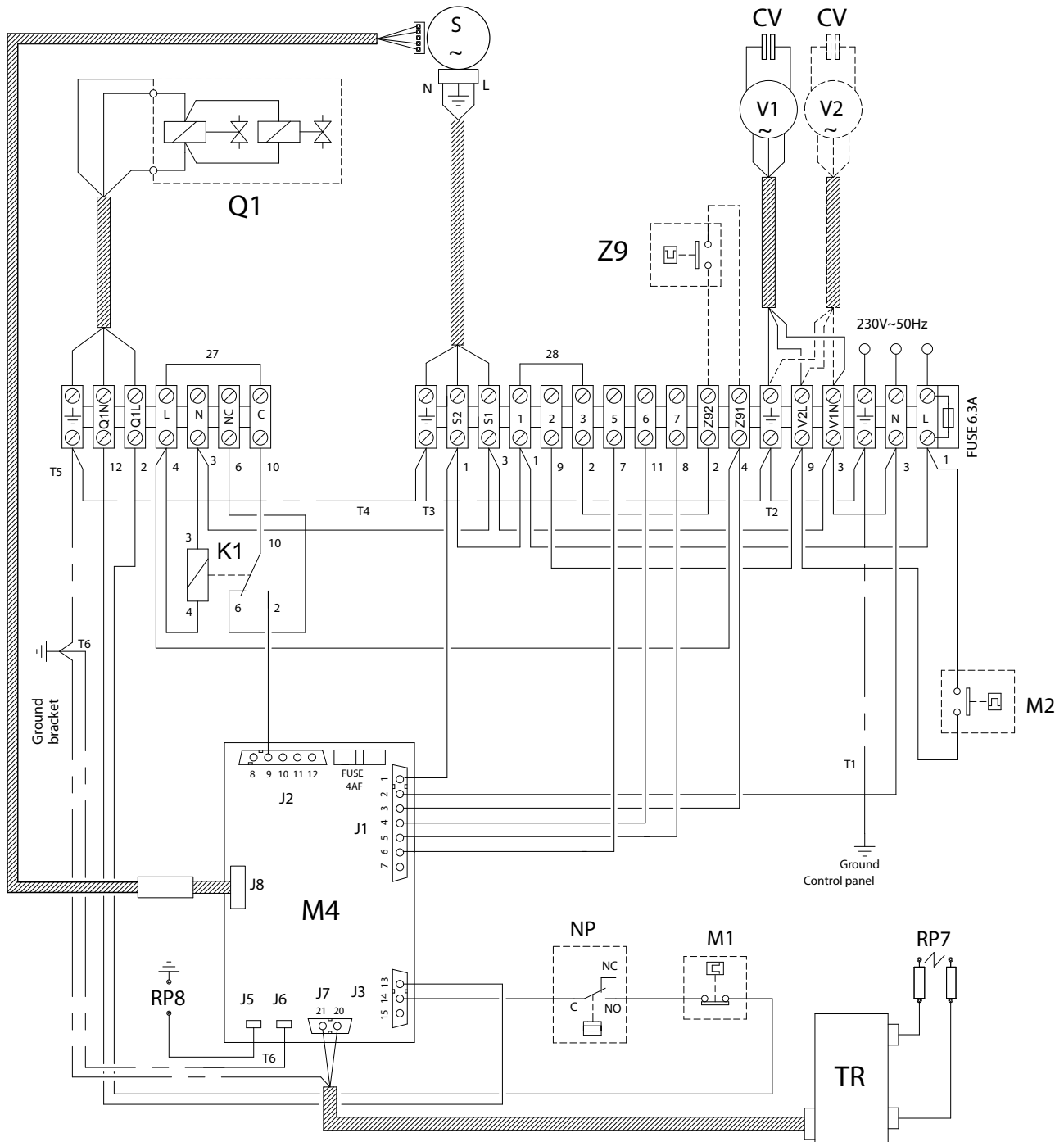

CV	Fan condenser	RP8	Flame sensor
K1	Internal modulation relay	S	Blower
M1	Limit thermostat	TR	Ignition transformer
M2	Fan thermostat	V1-V2	Fan
M4	Flame controller	Z9	External request (not supplied)
NP	Pressure switch	27	Power level control contact
Q1	Gas valve	28	Winter mode activation contact
RP7	Ignition electrodes		

1.5 OPERATION MODE

The Next-R gas unit heater can be operated on two heat output levels (maximum and minimum), keeping the fan speed constant.

To select the power level it is necessary to use a suitable control device (Paragraph 1.6 p. 22).

OTRG005 thermoregulators, OCDS008 digital chronothermostat and OSWR000 Genius software for remote management, all provide automated control of the two power levels.

In case of different control devices (OCDS012, OCTR000 or external request), power levels must be managed by opening or closing contact 27 (Figures 1.14 p. 20 and 1.15 p. 21). In detail:

- ▶ contact 27 closed: maximum power operation
- ▶ contact 27 open: minimum power operation

1.6 CONTROLS

1.6.1 Control device

The appliance may only work if it is connected to a control device, selected from:

1. OCDS012 1-key basic control
2. OCTR000 2-key basic control
3. OTRG005 thermoregulator
4. OCDS008 digital chronothermostat (only in association with OTRG005 thermoregulator)
5. OSWR000 Genius software for remote management of gas unit heaters (only in association with OTRG005 thermoregulator)
6. External request

1.6.2 OCDS012 1-key basic control

Figure 1.16 OCDS012 1-key basic control



Its functions are:

- ▶ Light signalling the status of the flame lockout.
- ▶ Reset of the flame lockout.

It does not allow to control the switching on and off of the unit for space heating, nor for the summer ventilation, nor the power modulation.

For further details and diagrams see Paragraph 4.4.1 p. 35.

An external request (Paragraph 1.6.7 p. 23) must be used to control the operation of the gas unit heater.

1.6.3 OCTR000 2-key basic control

Figure 1.17 OCTR000 2-key basic control



Its functions are:

- ▶ Light signalling the status of the flame lockout.
- ▶ Reset of the flame lockout.
- ▶ Summer ventilation mode activation.

It does not allow to control the switching on and off of the unit for space heating, nor the power modulation.

For further details and diagrams see Paragraph 4.4.2 p. 35.

An external request (Paragraph 1.6.7 p. 23) must be used to control the operation of the gas unit heater.

1.6.4 OTRG005 thermoregulator

Figure 1.18 OTRG005 thermoregulator



The thermoregulator is a device that can directly manage wall-mounted gas unit heaters: the serial interface makes it possible to create cascade systems managed by a single chronothermostat (optional OCDS008, described in Paragraph 1.6.5 p. 23), with considerable advantages in terms of thermoregulation, especially in large spaces.

The main functions are:

- ▶ Turning the gas unit heater on/off.
- ▶ Ambient temperature measurement by NTC probe.
- ▶ Automatic management of power modulation.
- ▶ Diagnostics.
- ▶ Reset of the flame lockout.
- ▶ Gas unit heater data display and parameters setting.
- ▶ Space heating and summer ventilation setpoint setting.
- ▶ Summer ventilation mode activation.
- ▶ Possibility of creating cascaded systems.
- ▶ Possibility of remote management via Modbus.

For further details and diagrams see OTRG005 thermoregulator instruction sheet and Paragraph 4.4.3 p. 35.

1.6.5 OCDS008 digital chronothermostat

Figure 1.19 OCDS008 digital chronothermostat



OCDS008 digital chronothermostat integrates the functions of room temperature control and remote control of the gas unit heaters heating system in a single interface, specifically designed to make all functions available to the user in a clear and intuitive way.

It may be used only in association with the OTRG005 thermoregulator.

The main functions are:

- ▶ Gas unit heaters cascade system management (up to 10).
- ▶ Time programming on a weekly basis on 3 temperature levels.
- ▶ Diagnostics.
- ▶ Reset.
- ▶ Gas unit heater data display and parameters setting.
- ▶ Space heating and summer ventilation setpoint setting.
- ▶ Automatic management of power modulation.
- ▶ Summer ventilation mode activation.

For further details and diagrams see OCDS008 digital chronothermostat instruction sheet and Paragraph 4.4.4 p. 36.

1.6.6 OSWR000 Genius software for remote management of gas unit heaters

This is a software that allows, through the OTRG005 thermoregulators, to centralize the management of up to 100 gas unit heaters, allowing them to be freely divided into zones, for an even more personalized heating management.

If the PC on which the software is installed is accessible remotely, the software allows remote management of the whole heating system from multiple devices, as well as sending emails to report any anomalies to the gas unit heaters or to the heating system.

The main functions are:

- ▶ Centralized system to control up to 100 gas unit heaters.
- ▶ Division of gas unit heaters into zones, up to 10 different zones.
- ▶ Independent or centralized gas unit heaters control.
- ▶ Remote control of the system from multiple devices.
- ▶ Diagnostics, also by email.
- ▶ Reset.
- ▶ Gas unit heater data display and parameters setting.
- ▶ Space heating and summer ventilation setpoint setting.
- ▶ Automatic management of power modulation.
- ▶ Summer ventilation mode activation.

For further details and diagrams see OSWR000 Genius software instruction sheet and Paragraph 4.4.5 p. 37.

1.6.7 External request

The appliance may also be controlled via generic enable devices (e.g. thermostat, timer, switch, contactor...) fitted with voltage-free NO contact.

Control through external request may be used on different contacts, available on the Next-R unit terminal block (Figures 1.14 p. 20 and 1.15 p. 21), to realize different features. In detail:

- ▶ Contact Z9 activates space heating operation.
- ▶ Contact 28 activates winter mode (open contact 1-2 at the same time).
- ▶ Contact 1-2 activates summer mode (open contact 28 at the same time).
- ▶ Contact 27 manages the two power levels of the unit.
- ▶ Contact 5-6 activates flame locking state indicator lamp.
- ▶ Contact 5-7 activates flame lockout reset.

For managing the request signal (Z9 contact), Robur provides as optional different models of thermostats and chronothermostats. For a list of thermostats and chronothermostats available as optional, see Paragraph 1.6.8 p. 23.

For further details and diagrams see Paragraph 4.4.6 p. 38.

1.6.8 Other optional thermostats and chronothermostats

For managing the request signal (Z9 contact), Robur provides as optional different models of thermostats and chronothermostats, listed below.

- ▶ Room thermostat with ON/OFF switch (optional O12301035)
- ▶ Sealed room thermostat IP55 (optional O12301025)
- ▶ Digital programmable chronothermostat (optional OCDS005)

1.7 TECHNICAL DATA

Table 1.2 Technical data

Axial fan models

			R15	R20	R30	R40	R50	R60	R80
Heating operation									
Heat input	nominal (1013 mbar - 15 °C)	kW	15,5	20,5	28,0	38,3	49,0	69,0	84,0
	minimum	kW	10,3	13,2	16,8	23,0	31,0	41,4	54,0
Heat output for each unit	nominal	kW	14,1	18,7	25,5	35,0	44,6	62,8	76,4
	minimum	kW	9,9	12,7	16,3	22,2	30,3	40,4	52,6
Efficiency	nominal heat input	%	91,0			91,5	91,0		
	minimal heat input	%	96,0	96,5	96,7	96,5	97,8	97,5	97,4
	useful at 100% heat input	%	90,7			91,2	90,6	90,5	90,6
Heat losses	to flue in operation	%	9,00			8,50	9,00		
	to casing in operation	%	0,30			0,40	0,50	0,40	
	with burner off	%				0,25			

(1) Values measured in an open area at maximum air flow. In a real installation, the thermal flow may reach greater distances than those given here (depending on the height of the ceiling and its thermal insulation).

			R15	R20	R30	R40	R50	R60	R80	
Temperature rise	nominal heat input	K	18,6	22,0	25,0	24,8	26,4	27,4	25,0	
	minimal heat input	K	13,0	15,0	15,9	15,7	18,0	17,6	17,2	
length of throw (residual speed < 0,5 m/s) (1)		m	13,0	15,0	18,0	20,0	25,0	28,0	40,0	
Outdoor temperature (dry bulb)	maximum	°C	35							
	minimum	°C	-15						0	
Electrical specifications										
Power supply	voltage	V	230							
	type	-	single-phase							
	frequency	Hz	50							
Electrical power absorption	nominal	kW	0,18	0,21	0,30	0,34	0,41	0,60		
fuse		A	6,3							
Degree of protection	fan motor	IP	54							
	appliance	IP	20							
Installation data										
Gas consumption	G20 natural gas (nominal)	m ³ /h	1,64	2,17	2,96	4,05	5,18	7,30	8,89	
	G25 (nominal)	m ³ /h	1,91	2,52	3,45	4,71	6,03	8,49	10,34	
	G25.1 (nominal)	m ³ /h	1,91	2,52	3,44	4,71	6,02	8,48	10,32	
	G25.3 (nominal)	m ³ /h	1,86	2,47	3,37	4,61	5,90	8,30	10,11	
	G27 (nominal)	m ³ /h	2,00	2,65	3,61	4,94	6,33	8,91	10,84	
	G2.350 (nominal)	m ³ /h	2,28	3,01	4,12	5,63	7,20	10,14	-	
	G30 (nominal)	kg/h	1,22	1,62	2,21	3,02	3,86	5,44	6,63	
Air flow	nominal (Delta T = 15 °C)	m ³ /h	2222	2460	2900	4010	4770	6470	8670	
	type	-	M						F	
Gas connection	thread	"	3/4							
	diameter (Ø)	mm	80							
Flue gas exhaust	residual head	Pa	70		90	80	100	130		
	type of installation	-	B23, C13, C33, C53, C63							
Combustion air intake connection	diameter (Ø)	mm	80							
recommended height		m	2,2	2,5	3,0 ÷ 3,5					
sound power L _w (max)		dB(A)	74,5	75,5	77,0	78,0	81,0	82,0	90,5	
sound pressure L _p at 5 metres (max)		dB(A)	52,5	53,5	55,0	56,0	59,0	60,0	68,5	
Dimensions	width	mm	678		735		929	1120	1320	
	depth	mm	557		731		746	731	746	
	height	mm	480							
Weight	in operation	kg	26	28	51	56	64	78	91	
General information										
number of heat exchangers		-	1	2	3	5	6	8		
type of heat exchangers		-	pipe			tower				
number of fans		-	1						2	

(1) Values measured in an open area at maximum air flow. In a real installation, the thermal flow may reach greater distances than those given here (depending on the height of the ceiling and its thermal insulation).

Centrifugal fan models

			R30 C	R40 C	R50 C	R80 C	
Electrical specifications							
Electrical power absorption	nominal	kW	0,38	0,68	1,38	1,40	
fuse		A	6,3		10,0		
Degree of protection	fan motor	IP	44				
	appliance	IP	20				
Installation data							
Air flow	at maximum available head	m ³ /h	1900	3400	4700	7000	
	nominal (Delta T = 15 °C)	m ³ /h	2900	4000	5350	8550	
maximum useful pressure head		Pa	120		240	120	
minimum pressure drop on heat flow delivery		Pa	0		50		
Dimensions	width	mm	775			969	1359
	height	mm	777				
	depth	mm	1031	1072	1138	1073	
Weight	in operation	kg	68	80	92	129	

Vertical downflow models

R30 V	R40 V	R50 V
The technical data of these models are identical to those of the corresponding axial models, with the exception of the installation height		

2 TRANSPORT AND POSITIONING

2.1 WARNINGS

Damage from transport or installation

The manufacturer shall not be liable for any damage during appliance transport and installation.

On-site inspection

- Upon arrival at the site, ensure there is no transport damage on packing, metal panels or to the thermoformed door.
- After removing the packing materials, ensure the appliance is intact and complete.

Packing

- Only remove the packing after placing the appliance on site.
- Do not leave parts of the packing within the reach of children (plastic, polystyrene, nails...) since they are potentially dangerous.

Weight

- The lifting equipment must be suitable for the load.
- Lift up the unit and secure it to its support bracket (Paragraph 2.5 p. 27).

2.2 HANDLING AND LIFTING

- ▶ Always handle the appliance in its packing, as delivered by the factory.
- ▶ Comply with safety regulations at the installation site.

2.3 APPLIANCE POSITIONING

The appliance must be installed in the room to be heated.

Figure 2.1 Airflow distribution

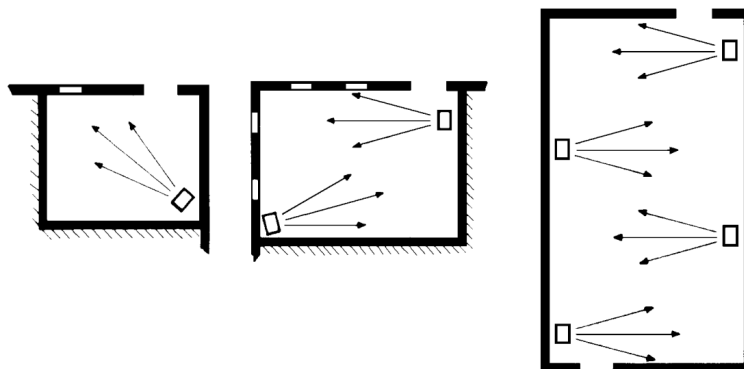

2.4 MINIMUM CLEARANCE DISTANCES

2.4.1 Distances from combustible or flammable materials

- ▶ Keep the appliance away from combustible or flammable



The appliance is not designed for outdoor installation.

2.3.1 Where to install the appliance



The wall or structure on which the unit is to be installed must be load-bearing or, in any case, suitable for supporting its weight.



Installation must not be made on walls with poor strength that do not guarantee adequate resistance to the stresses produced by the appliance. The manufacturer assumes no responsibility if the appliance is installed on surfaces or walls that are not suitable to support its weight.



Vertical downflow gas unit heaters must be installed with the warm air delivery downwards. The gas unit heater must be horizontal in relation to its longitudinal axis.



The appliance's flue gas exhaust must not be immediately close to openings or air intakes of buildings, and must comply with safety and environmental regulations.

To obtain the maximum system efficiency it is advisable to comply with the following rules:

- ▶ Take care that the air flow does not directly impinge on the staff (by tilting the front grille louvres appropriately).
- ▶ Take any obstacles into account (pillars or other).
- ▶ Consider length of throw of the unit (Table 1.2 p. 23).
- ▶ For better heat distribution in the case of multiple unit installations, create alternate flows of warm air (see Figure 2.1 p. 25).
- ▶ In some cases it may also be suitable to place the units close to the main doors, so that they can also operate as air barriers when doors are opened.

materials or components, in compliance with applicable regulations.

2.4.2 Clearances around the appliance

i The minimum clearance distances are required for safety,

2.4.2.1 Axial gas unit heaters

Figure 2.2 Clearances

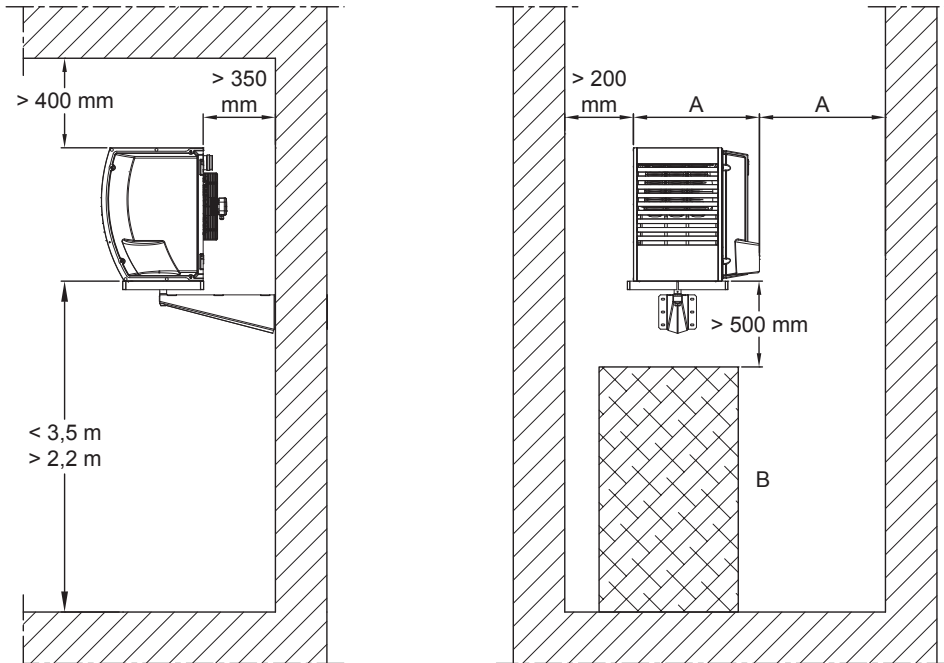

A Gas unit heater width

B Object or structure underneath the gas unit heater

i The recommended height from the floor to the gas unit heater base is 2,2 to 3,5 m (see Figure 2.2 p. 26). Installing the gas unit heaters at heights below 2,2 m from the floor is not recommended.

2.4.2.2 Centrifugal gas unit heaters

The position of gas unit heaters with centrifugal fan must consider the position of the warm air duct. This must be suitably sized and verified in relation to the air flow rate and the head of the centrifugal fan (Paragraph 3.5 p. 34).

2.4.2.3 Vertical downflow gas unit heaters

A minimum distance of 1 m from all sides is required around the vertical downflow gas unit heater.

Table 2.1 p. 26 shows recommended minimum and maximum heights for installation and the air jet range to the floor, depending on the actual height of the gas unit heater from the floor (indicated with H).

i For vertical downflow gas unit heaters, the louvres of the delivery grille must be in the fully open position.

Figure 2.3 Clearances

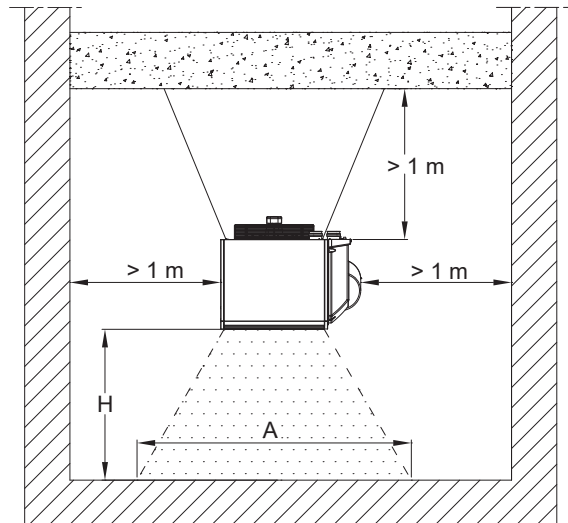

A Air jet range

H Gas unit heater installation height

Table 2.1 Installation height and air jet range for vertical downflow gas unit heaters

			R15	R20	R30 V	R40 V	R50 V
Hmin	Minimum height	m	3,0	3,0	3,5	5,0	6,0
Hmax	Maximum height	m	4,0	4,0	6,0	7,0	8,0
A	Air jet range	m	16-H	16-H	20-H	22-H	24-H

E.g.: if a R40 V is installed at 6 m from the ground (H = 6), the air

jet range value (A) is $(22 - 6) = 16$ m.

2.5 SUPPORT BRACKET

Robur provides easy mounting support brackets as an optional, suitably designed for Next-R series gas unit heaters, which allow simplifying the wall fixing.

If you do not want to use these options, refer to Figure 2.4 p. 27. When fixing the unit to the support brackets, use 4 M10 bolts.

Figure 2.4 Installation with support bracket

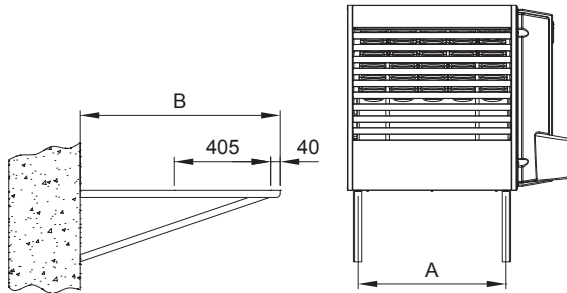

A Gas unit heater fixing points centre distance
B Support bracket length

Table 2.2 Support bracket dimensions for axial gas unit heaters

	R30	R40	R50	R60	R80
A	370	370	620	810	1010
B	840				

Table 2.3 Support bracket dimensions for centrifugal gas unit heaters

	R30 C	R40 C	R50 C	R80 C
A	370	370	620	1010
B	1400			

For vertical downflow gas unit heater, indications are given on how to proceed with the gas unit heater suspension.

2.5.1 Axial gas unit heaters

For axial gas unit heaters the following support brackets are available as optional:

- ▶ OSTF020 revolving wall support bracket (R15, R20 models)
- ▶ O19800020 revolving wall support bracket (R30, R40 models)
- ▶ O19800026 revolving wall support bracket (R60 model)
- ▶ O19800028 revolving wall support bracket (R80 model)
- ▶ OKMN000 revolving wall support bracket (R50 model)
- ▶ OSTF009 support bracket 1,4 m length
- ▶ OSTF005 tubular support bracket (modelli R30, R40, R50, R60, R80)

2.5.2 Centrifugal gas unit heaters

For centrifugal gas unit heaters, the following mounting brackets are available as optional:

- ▶ OSTF009 support bracket 1,4 m length

2.5.3 Vertical downflow gas unit heaters

Vertical downflow gas unit heaters do not require wall mounting brackets, as they must be suspended from the ceiling of the heated room.

The gas unit heater is equipped, on the fan side, with appropriate vertical suspension brackets, to which the gas unit heater supports can be connected (Figure 2.5 p. 27).

The mounting must be such that the brackets are not stressed outwards, but always on axis with the brackets. A minimum of

rotation around the axis of the fixing screw is permitted.

The suspension brackets on the upper side of the gas unit heater (flue gas outlet side) are already fitted, while those on the lower side must be fitted by the installer (Figure 2.6 p. 27).



Do not use other systems to hang the gas unit heater than the provided brackets.



The R15 and R20 gas unit heaters are not equipped with vertical suspension brackets, as the installation with vertical downflow is carried out by means of the revolving bracket OSTF020 (available as an optional, Paragraph 2.5.4 p. 27).

Figure 2.5 Under ceiling support brackets

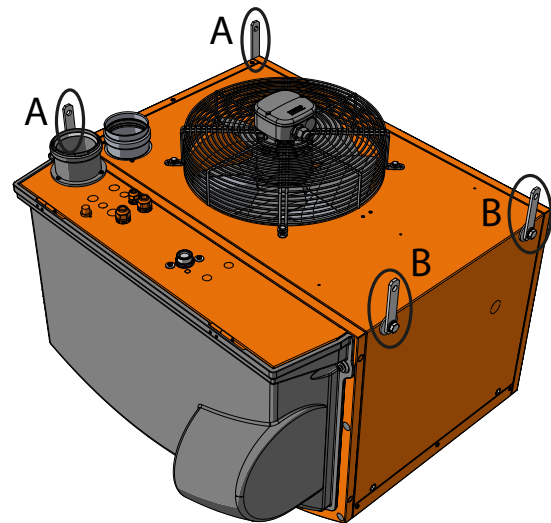

A Vertical suspension brackets, already fitted on the gas unit heater
B Supplied vertical suspension brackets, to be fitted on the gas unit heater

Figure 2.6 Fitting of lower vertical suspension brackets for vertical downflow gas unit heaters

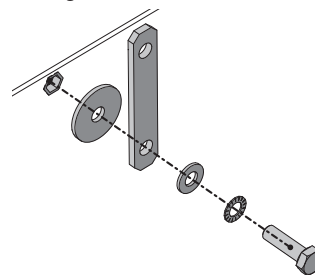

2.5.4 OSTF020 revolving wall support bracket (R15, R20 models)

For R15 and R20 gas unit heaters, the OSTF020 revolving bracket (available as an optional) allows the gas unit heater to be oriented both horizontally, or inclined by 45°, or with vertical downflow (inclined by 90°), always using the same bracket.

The bracket must in any case be positioned on the wall, even in the case of vertical downflow (it is not possible to suspend the gas unit heater in this case, as it is not equipped with vertical suspension brackets).

The bracket is supplied with bolts and the rear support plate.

For mounting instructions of the bracket, refer to the relevant

instruction sheet.

Figure 2.7 OSTF020 bracket positions

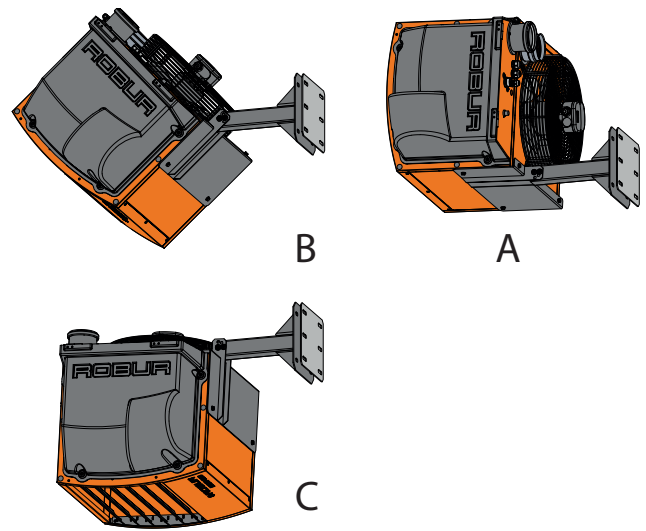

A Bracket in horizontal position (0°) C Bracket at 90°
 B Bracket at 45°

3 HEATING ENGINEER

3.1 WARNINGS



Read the warnings in Chapter III.1 p. 4, providing important information on regulations and on safety.



Compliance with installation standards

Installation must comply with applicable regulations in force, based on the installation Country and site, in matters of safety, design, implementation and maintenance of:

- heating systems
- gas systems
- flue gas exhaust
- flue gas condensate drain



Installation must also comply with the manufacturer's provisions.

3.2 FUEL GAS SUPPLY

3.2.1 Gas connection

- ▶ 3/4" M (R15, R20, R30, R40, R50 models)
- ▶ 3/4" F (R60, R80 models)

on the rear, to the left (see dimensional diagrams, Paragraph 1.2 p. 8).

- ▶ Install an anti-vibration connection between the appliance and the gas piping.

3.2.2 Mandatory shut-off valve

- ▶ Provide a gas shut-off valve (manual) on the gas supply line, next to the appliance, to isolate it when required.
- ▶ Provide a three-piece pipe union or similar system to allow the gas unit heater to be disconnected from the gas supply.
- ▶ Perform connection in compliance with applicable regulations.

3.2.3 Gas pipes sizing

The gas pipes must not cause excessive pressure drops and, consequently, insufficient gas pressure for the appliance.

3.2.4 Supply gas pressure



This appliance is equipped for a maximum gas supply pressure of 50 mbar.

The appliance's gas supply pressure, both static and dynamic, must comply with Table 3.1 p. 28, with tolerance $\pm 15\%$.



Non compliant gas pressure may damage the appliance and be hazardous.

Table 3.1 Network gas pressure of Next-R series gas unit heaters

Product category	Country of destination	Gas supply pressure [mbar]							
		G20	G25	G25.1	G25.3	G2.350	G27	G30	G31

The appliance gas supply pressure, both static and dynamic, must comply with the values in the Table, with a tolerance of $\pm 15\%$.

II _{2H3B/P}	AL, BG, CH, CY, CZ, DK, EE, FI, GR, HR, IT, LT, LV, MK, NO, RO, SE, SI, SK, TR	20						30	30
	AT, CH	20						50	50
II _{2H3P}	AL, BG, CH, CZ, ES, GB, GR, HR, IE, IT, LT, LV, MK, PT, SI, SK, TR	20							37
	RO	20							30
	AT	20							50
II _{2ELL3B/P}	DE	20	20					50	50
II _{2ESi3P}	FR	20	25						37
II _{2Ei3P}		20	25						37
II _{2H3B/P}	HU	25						30	30
II _{2HS3B/P}		25		25				30	30
II _{2E3P}	LU	20							50
II _{2L3B/P}	NL		25					30	30
II _{2L3P}			25						37
II _{2EK3B/P}		20			25			30	30
II _{2EK3P}		20			25				30
II _{2E3B/P}		20						37	37
I _{2E}	PL	20							
II _{2ELWLS3B/P}		20				13	20	37	37
II _{2ELWLS3P}		20				13	20		37
I _{2E(R)}	BE	20	25						
I _{2E(S)}		20	25						
I _{3P}									37
I _{3P}	IS								30
I _{2H}	LV	20							
I _{3B/P}	MT							30	30
I _{3B}								30	

The appliance gas supply pressure, both static and dynamic, must comply with the values in the Table, with a tolerance of $\pm 15\%$.

3.2.5 Vertical pipes and condensate

- ▶ If needed, vertical gas pipes must be fitted with siphon and discharge of the condensate that may form inside the pipe.
- ▶ If needed, insulate the piping.

3.2.6 LPG pressure reducers

With LPG the following must be installed:

- ▶ A first stage pressure reducer, close to the liquid gas tank.
- ▶ A second stage pressure reducer, close to the appliance.

3.3 COMBUSTION PRODUCTS EXHAUST



Compliance with standards

The appliance is approved for connection to a combustion products exhaust duct for the types shown in Table 1.2 p. 23.

3.3.1 Flue gas exhaust connection

- ▶ $\varnothing 80$ mm with gasket, on the rear, at the top (see dimensional diagrams, Paragraph 1.2 p. 8).

For all models, it is possible to move the fumes gas outlet connection from the rear position to the top of the unit.



How to move the fumes gas outlet

1. Remove the gas unit heater top panel.
2. Remove the blind cover of the upper flue gas exhaust (detail 7 in the dimensional diagrams, Paragraph 1.2 p. 8) from the top panel.
3. Unscrew the three screws fixing the flue gas exhaust to the rear collar.
4. Position the flue gas exhaust in the lead-in in the top panel.

5. Secure the flue gas exhaust to the upper lead-in with the three screws.
6. Fit the blind cover on the rear flue gas exhaust.
7. Fit the gas unit heater top panel back on.

3.3.2 Combustion air intake fitting

- ▶ $\varnothing 80$ mm with gasket, on the rear, at the top (see dimensional diagrams, Paragraph 1.2 p. 8).

3.3.3 Installation types



The lengths in following Tables are intended for installations where the air and/or flue gas exhaust ducts follow linear paths as shown in the respective Figures. Otherwise, you must proceed with the calculation of the pressure drop (Paragraph 3.3.4 p. 31).



If ducts other than those supplied by the manufacturer are used, make sure that they are suitable for the unit on which they are installed. In particular, the temperature class of the duct must be appropriate for the operating characteristics of the unit, and must also respect the chemical-physical stability of the system itself.



In any case, use approved ducts according to the type of installation to be made. Upon request, Robur can supply suitable rigid pipes, coaxial ducts and terminals.

Gas unit heaters of the Next-R series can be installed to one of the following ways.

3.3.3.1 B23 type installation with wall flue gas exhaust pipe

Figure 3.1 B23 type installation with Ø 80 flue gas exhaust pipe

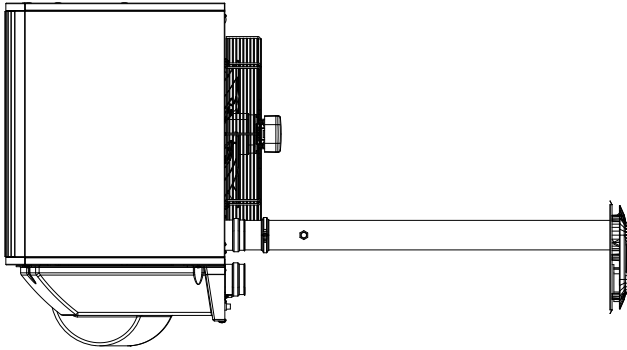

3.3.3.3 C13 type installation with separate ducts

Figure 3.3 C13 type installation with Ø 80 separate ducts

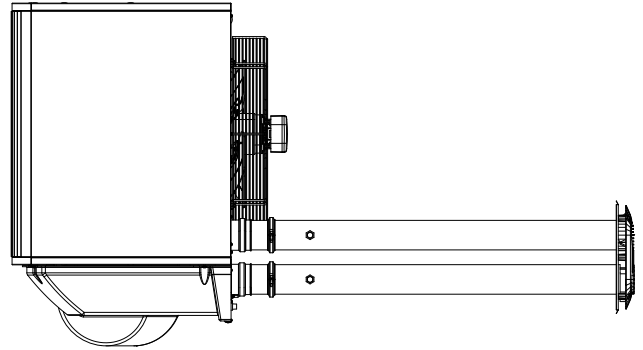

Table 3.2 B23 type maximum allowed length

	Indicative maximum lengths (m)		
	Flue gas exhaust pipe		
	Ø 80	Ø 100	Ø 110
R15	30	30	30
R20	30	30	30
R30	30	30	30
R40	28	30	30
R50	16	30	30
R60	10	30	30
R80	9	30	30

Table 3.4 C13 type maximum allowed length with separate ducts

	Indicative maximum lengths (m)					
	Air pipe			Flue gas exhaust pipe		
	Ø 80	Ø 100	Ø 110	Ø 80	Ø 100	Ø 110
R15	30	30	30	30	30	30
R20	30	30	30	30	30	30
R30	25	30	30	25	30	30
R40	19	30	30	19	30	30
R50	10	30	30	10	30	30
R60	7	22	30	7	22	30
R80	6	20	26	6	20	26

3.3.3.2 B23 type installation with roof flue gas exhaust pipe

Figure 3.2 B23 type installation with Ø 80 roof flue gas exhaust pipe

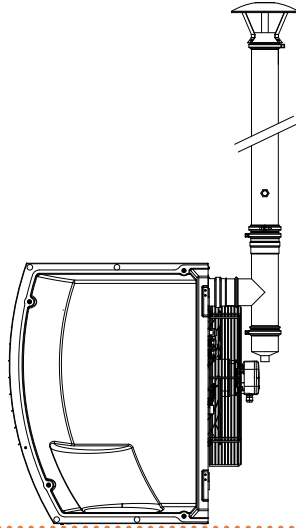

Table 3.3 B23 type maximum allowed length with roof flue gas exhaust pipe

	Indicative maximum lengths (m)		
	Flue gas exhaust pipe		
	Ø 80	Ø 100	Ø 110
R15	30	30	30
R20	30	30	30
R30	30	30	30
R40	25	30	30
R50	13	30	30
R60	7	24	30
R80	6	20	30

3.3.3.4 C13 type installation with wall coaxial terminal

Figure 3.4 C13 type installation with wall coaxial terminal and Ø 80 ducts

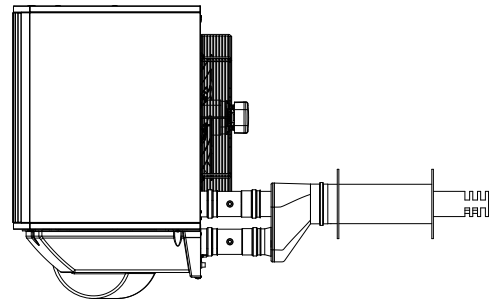
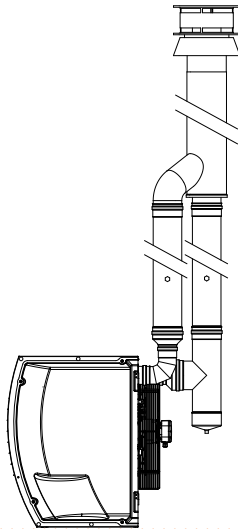

Table 3.5 C13 type maximum allowed length with 80/125 wall coaxial terminal (optional OSCR007) and Ø 80 ducts

	Indicative maximum lengths (m)	
	Air pipe	Flue gas exhaust pipe
R15	30	30
R20	30	30
R30	22	22
R40	16	16
R50	8	8
R60	-	-
R80	-	-

Table 3.6 C13 type maximum allowed length with 130/180 wall coaxial terminal (optional OKTC004)

	Indicative maximum lengths (m)			
	Air pipe		Flue gas exhaust pipe	
	Ø 80	Ø 130	Ø 80	Ø 130
R15	30	30	30	30
R20	30	30	30	30
R30	24	30	24	30
R40	18	30	18	30
R50	9	30	9	30
R60	6	30	6	30
R80	5	30	5	30

3.3.3.5 C33 type installation with roof coaxial terminal**Figure 3.5** C33 type installation with roof coaxial terminal**Table 3.9** C33 type maximum allowed length with 130/210 roof coaxial terminal (optional OKTC001)

	Indicative maximum lengths (m)					
	Air pipe			Flue gas exhaust pipe		
	Ø 80	Ø 110	Ø 130	Ø 80	Ø 110	Ø 130
R15	30	30	30	30	30	30
R20	30	30	30	30	30	30
R30	21	30	30	21	30	30
R40	15	30	30	15	30	30
R50	7	30	30	7	30	30
R60	3	26	30	3	26	30
R80	2	21	30	2	21	30

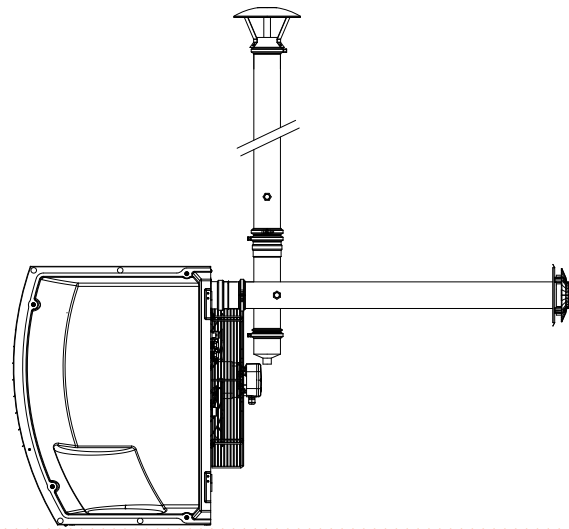
3.3.3.6 C53 type installation with separate ducts**Figure 3.6** C53 type installation with Ø 80 separate ducts**Table 3.7** C33 type maximum allowed length with 80/125 roof coaxial terminal (optional OSCR008) and Ø 80 ducts

	Indicative maximum lengths (m)	
	Air pipe	Flue gas exhaust pipe
R15	30	30
R20	30	30
R30	18	18
R40	12	12
R50	3	3
R60	-	-
R80	-	-

Table 3.8 C33 type maximum allowed length with 100/150 roof coaxial terminal (optional OSCR009)

	Indicative maximum lengths (m)			
	Air pipe		Flue gas exhaust pipe	
	Ø 80	Ø 100	Ø 80	Ø 100
R15	30	30	30	30
R20	30	30	30	30
R30	19	30	19	30
R40	14	30	14	30
R50	5	21	5	21
R60	1	10	1	10
R80	-	1	-	1

Table 3.10 C53 type maximum allowed length with separate ducts

	Indicative maximum lengths (m)			
	Air pipe	Flue gas exhaust pipe		
		Ø 80	Ø 100	Ø 110
R15	1	30	30	30
R20	1	30	30	30
R30	1	30	30	30
R40	1	24	30	30
R50	1	12	30	30
R60	1	7	29	30
R80	1	6	26	30

3.3.4 Sizing and installing combustion air/exhaust fumes ducts

In order to dimension the duct system, the total pressure drop of the system must be calculated.

The total allowed pressure drop in the flue gas exhaust system depends on the unit model (Table 3.11 p. 32).

The pressure drops of the flue and air pipes available as Robur optional are shown in Table 3.12 p. 32.

Table 3.13 p. 32 shows the pressure drops for Ø 100 flue and air pipes in aluminium, available on the market.

The pressure drops of the coaxial pipes available as Robur optional are shown in Table 3.14 p. 32.

Resistance from the separate terminals are negligible since they are very low.

When designing, it must be checked that the total pressure drop of the piping system is lower than the residual head of the appliance (Table 3.11 p. 32). An example of how to calculate pressure drops is given in Paragraph 3.3.5 p. 33.

The maximum lengths of air and flue gas exhaust pipes, depending on the type of installation, are shown in tables under the installation type figures, described in Paragraph 3.3.3 p. 29.

installation will be permitted if the total pressure drop is lower than the residual head of the appliance (Table 3.11 p. 32).



The above lengths are intended to be approximate values for standard installations where the air and flue gas exhaust ducts follow linear paths as shown in the respective figures. Otherwise, you must proceed with the calculation of the pressure drop (Paragraph 3.3.5 p. 33):



The Ø 80, 110 and 130 pipes available as Robur optional are made of stainless steel, while the Ø 100 adapters available as Robur optional are made of aluminium.

Table 3.11 Data for the calculation of the air/fumes system with pipes found on the market

				R15	R20	R30	R40	R50	R60	R80
Installation data										
Flue temperature	Nominal heat input	G20	°C	210,0	200,0	218,0	195,0	196,0	180,0	220,0
Fumes flow rate	Nominal heat input	G20	kg/h	27	35	48	65	83	116	142
CO₂ percentage in flue gases	Nominal heat input	G20	%	9,0	9,2	8,5	9,2	9,0	9,4	8,3
Flue gas exhaust	residual head		Pa	70			90	80	100	130

Table 3.12 Data for the calculation of the air/fumes system with Ø 80/110/130 pipes available as optional

				R15	R20	R30	R40	R50	R60	R80
Flue gas exhaust pressure drop										
Ø 80 mm	Pipe	1 m	Pa	0,7	1,0	1,9	3,2	5,0	9,2	13,4
	Elbow	90°	Pa	0,9	1,5	2,8	5,0	8,0	15,4	22,7
	Tee		Pa	2,0	3,1	5,6	9,6	15,0	27,7	40,3
Ø 110 mm	Pipe	1 m	Pa	0,1	0,2	0,4	0,7	1,1	1,9	2,8
	Elbow	90°	Pa	0,3	0,4	0,8	1,4	2,2	4,3	6,3
	Tee		Pa	0,4	0,7	1,2	2,1	3,2	5,8	8,4
Ø 130 mm	Pipe	1 m	Pa	0,1		0,2	0,3	0,5	0,9	1,2
	Elbow	90°	Pa	0,1	0,2	0,4	0,7	1,1	2,2	3,2
	Tee		Pa	0,2	0,3	0,5	0,9	1,4	2,6	3,7
Air intake pressure drop										
Ø 80 mm	Pipe	1 m	Pa	0,3	0,5	0,9	1,5	2,4	4,4	6,3
	Elbow	90°	Pa	0,4	0,7	1,2	2,2	3,6	6,9	10,2
	Tee		Pa	1,0	1,5	2,6	4,5	7,1	13,1	19,0
Ø 110 mm	Pipe	1 m	Pa	0,1		0,2	0,3	0,5	0,9	1,3
	Elbow	90°	Pa	0,1	0,2	0,3	0,6	1,0	1,9	2,8
	Tee		Pa	0,2	0,3	0,6	1,0	1,5	2,7	3,9
Ø 130 mm	Pipe	1 m	Pa	0,1				0,2	0,4	0,6
	Elbow	90°	Pa	0,1		0,2	0,3	0,5	1,0	1,4
	Tee		Pa	0,1		0,3	0,4	0,7	1,2	1,8

Table 3.13 Data for the calculation of the air/fumes system with Ø 100 pipes

				R15	R20	R30	R40	R50	R60	R80
Flue gas exhaust pressure drop										
Ø 100 mm	Pipe	1 m	Pa	0,2	0,4	0,6	1,1	1,6	3,0	4,3
	Elbow	90°	Pa	0,4	0,6	1,1	2,0	3,2	6,1	9,0
	Tee		Pa	0,7	1,1	1,9	3,2	4,9	9,0	12,9
Air intake pressure drop										
Ø 100 mm	Pipe	1 m	Pa	0,1	0,2	0,3	0,5	0,8	1,4	2,0
	Elbow	90°	Pa	0,2	0,3	0,5	0,9	1,4	2,7	4,0
	Tee		Pa	0,3	0,5	0,9	1,5	2,3	4,3	6,1

Table 3.14 Data for the calculation of the air/fumes system with coaxial pipes available as optional

				R15	R20	R30	R40	R50	R60	R80
Coaxial exhaust pipe pressure drop										
Ø 80/125 mm	wall	Pa		5,9	6,4	8,0	11,7	17,5	-	-
	roof	Pa		6,2	8,1	11,0	20,4	37,0	-	-
Ø 130/180 mm	wall (1)	Pa		1,2	1,4	1,6	2,0	3,0	6,4	12,0
Ø 100/150 mm	roof	Pa		2,6	3,3	9,0	12,0	19,0	38,6	70,0
Ø 130/210 mm	roof	Pa		0,9	1,2	3,3	4,3	6,7	13,2	23,5

(1) Can be used only with OSTF009 support bracket



If horizontal flue gas exhaust pipes having lengths above 1 m are installed, the flue gas exhaust pipe must be mounted with a downward slope of 2 to 3 cm each 1-m

length (Figure 3.7 p. 33), to prevent condensate drops entering the unit.



If vertical flue gas exhaust pipes longer than 1,5 m are installed, at the base of the vertically mounted flue gas exhaust pipe a T-shaped piece must be fitted to collect the condensate, to prevent any condensate drops from entering the gas unit heater (Figure 3.2 p. 30).



For each 45° elbow an increment of 1,2 m in length should be added.

Figure 3.7 Slope of horizontal pipes

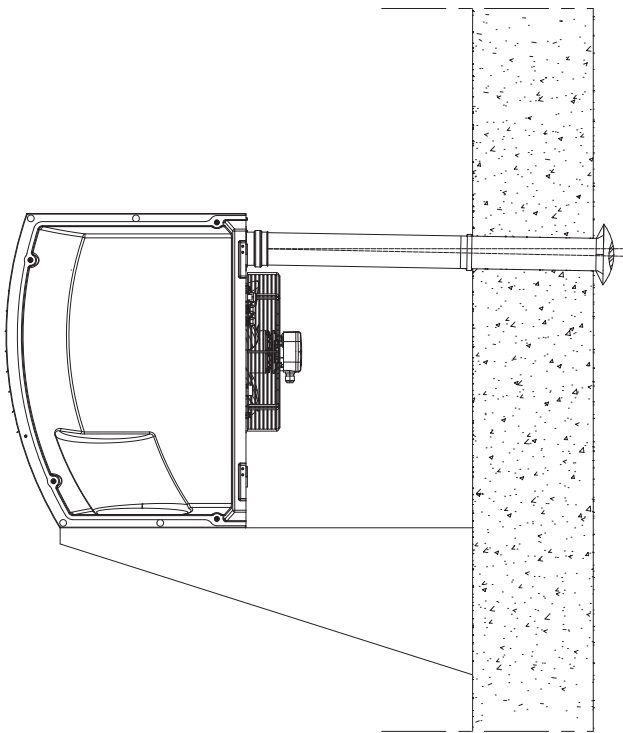

For proper installation of the wall external terminals for the flue gas exhaust and combustion air intake, follow the details given in Figure 3.8 p. 33.

Figure 3.8 Wall terminal position

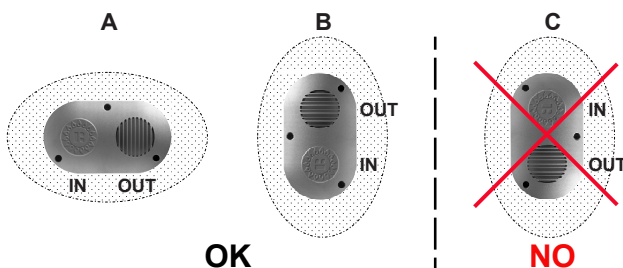

IN Combustion air intake
OUT Flue gas exhaust
A Recommended position (OK)

B Allowed position (OK)
C Position NOT allowed (NO)

3.3.5 Example of calculation

Let's assume to install a R60 in C13 type installation (Figure 3.3 p. 30). The air/fumes system will be realized with Ø 80 separate pipes in the following way:

- ▶ 7 m of Ø 80 flue gas exhaust pipe
- ▶ 1 90° Ø 80 elbow on the flue gas exhaust pipe

- ▶ 6 m of Ø 80 air pipe

It is therefore possible to proceed with the verification, remembering that the residual head is 100 Pa (see Table 3.11 p. 32).

- ▶ Ø 80 flue gas exhaust pipe
7 m x 9,2 Pa/m = 64,4 Pa

- ▶ 90° elbow
1 x 15,4 Pa = 15,4 Pa

- ▶ Ø 80 air pipe
6 m x 4,4 Pa/m = 26,4 Pa

Total pressure drop = 106,2 Pa

Total pressure drop of the piping system is greater than the residual head (100 Pa), therefore the installation is not allowed.

The installation can be done if one of the following steps is taken:

- ▶ Reduce the length of the air/fumes pipes.
- ▶ Increase pipe diameter, e.g. by using Ø 110. In this case the total pressure drop would be:

$$7 \text{ m} \times 1,9 \text{ Pa/m} = 13,3 \text{ Pa}$$

$$1 \times 4,3 \text{ Pa} = 4,3 \text{ Pa}$$

$$6 \text{ m} \times 0,9 \text{ Pa/m} = 5,4 \text{ Pa}$$

Total pressure drop = 23,0 Pa

which is therefore compatible with the residual head.

3.3.6 Vertical downflow gas unit heaters



For vertical downflow gas unit heaters, at the base of the vertically mounted flue gas exhaust pipe a T-shaped piece must be fitted to collect the condensate, to prevent any condensate drops from reaching the blower (Figure 3.9 p. 33).



Pay attention to the collection and the proper conveying of the condensate drain.

Figure 3.9 Example of a vertical downflow gas unit heater installation

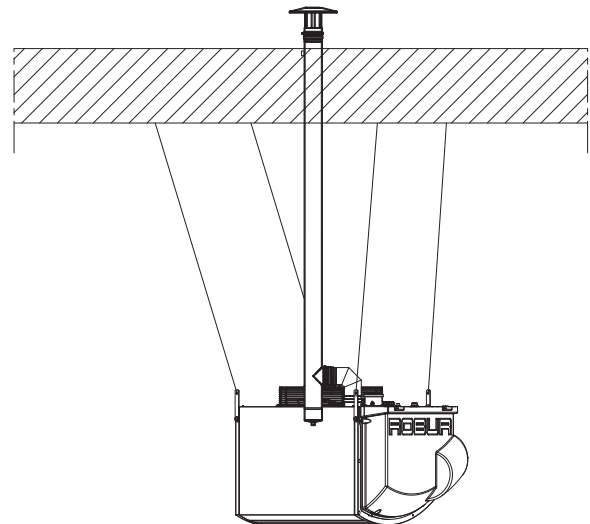

3.4 OPENING THE GRILLE LOUVRES



Protection devices

Wear appropriate protective equipment when handling the front grille louvres.

To ensure the correct operation of gas unit heaters fitted with a front grille, the louvres of the grille must be opened, as shown in Figure 3.10 p. 34.

Figure 3.10 Opening the gas unit heater grille louvres

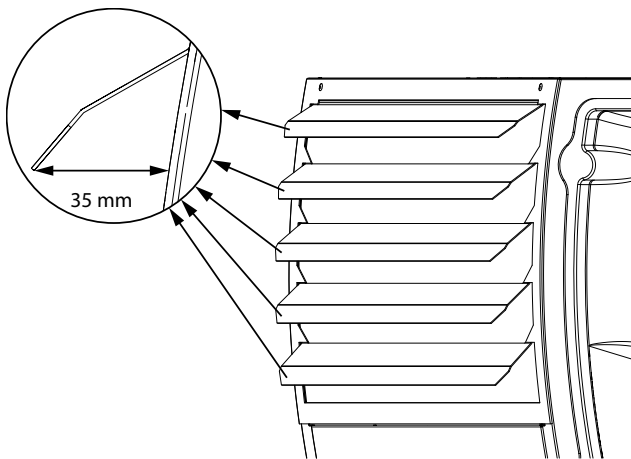

3.5 AIR DUCTING

Only models equipped with a centrifugal fan (Next-R C series) can be combined with air ducting systems, which can be positioned both on the air intake (with or without mixing chambers)

and on the delivery.
For this purpose, the delivery outlet of the Next-R C gas unit heaters is provided with fixing flanges for the delivery air ducting. Refer to the Paragraph 1.2.2 p. 14 for the dimensions of the flange connection.

i In order to avoid vibrations (possible source of noise and mechanical failures), it is advisable to install anti-vibration connections, easily removable for maintenance operation, at the connection between the gas unit heater and the air duct.

Set up the air ducting using a traditional sufficiently smooth sheet metal duct.

The insulation of the duct must be assessed, in order to avoid heat losses.

For the dimensioning of the air duct, consider the data of air flow and available head of the fan, summarized in Table 1.2 p. 23.

! Minimum pressure drop on heat flow delivery

In order to grant that the centrifugal fan operates within the operating limits in any situation, it is mandatory to ensure a minimum pressure drop on the air delivery. The minimum pressure drop values are detailed in Table 1.2 p. 23.

4 ELECTRICAL INSTALLER

4.1 WARNINGS

! Read the warnings in Chapter III p. 4, providing important information on regulations and on safety.

i Compliance with installation standards

Installation must comply with applicable regulations in force, based on the installation Country and site, in matters of safety, design, implementation and maintenance of electrical systems.

i Installation must also comply with the manufacturer's provisions.

! Live components

After placing the appliance in the final position, and prior to making electrical connections, ensure not to work on live components.

! Earthing

- The appliance must be connected to an effective earthing system, installed in compliance with regulations in force.
- It is forbidden to use gas pipes as earthing.

i Cable segregation

Keep power cables physically separate from signal ones.

! Do not use the power supply switch to turn the ap-

pliance on/off

- Never use the power supply switch to turn the appliance on and off, since it may be damaged in the long run (occasional blackouts are tolerated).
- To turn the appliance on and off, exclusively use the suitably provided control device.

4.2 ELECTRICAL SYSTEMS

Electrical connections provide:

- A. Power supply (Paragraph 4.3 p. 34).
- B. Control system (Paragraph 4.4 p. 35).

! How to make connections

All electrical connections must be made in the connection terminal block located near the electrical panel:

1. Ensure the appliance is not live.
2. To access the electrical panel of the unit, open the thermoformed door on the right side of the unit (detail 5 on dimensional diagrams, Paragraph 1.2 p. 8).
3. Insert cables through cable gland (detail 3 on dimensional diagrams, Paragraph 1.2 p. 8). PG9 cable glands are suitable for cables with diameters from 3,5 to 8 mm. PG13.5 cable glands are suitable for cables with diameters from 6 to 12 mm.
4. Identify the appropriate connection terminals.
5. Make the connections.
6. Close the thermoformed door.

4.3 ELECTRICAL POWER SUPPLY

Provide (by the installer) a protected single phase line (230 V 1-N 50 Hz) with:

- ▶ H05 VVF 3x1,5 mm² type cable with a maximum external di-

iameter of 12 mm.

- ▶ Bipolar disconnector with minimum contact opening of 3 mm.



How to connect the power supply

To connect the three-pole power supply cable:

1. Access the connection terminal block according to Procedure 4.2 p. 34.
2. Connect the three wires to the terminal block as shown in Figure 4.1 p. 35.
3. Provide the earth lead-in wire longer than live ones (last to be torn in the event of accidental pulling).

Figure 4.1 Appliance connection to the mains power supply

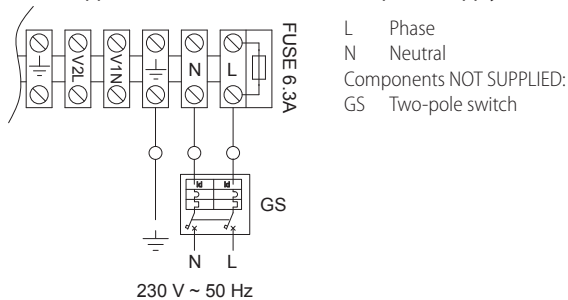

4.4 CONTROL SYSTEM

Six separate adjustment systems are provided, each with specific features, components and diagrams:

1. OCDS012 1-key basic control
2. OCTR000 2-key basic control
3. OTRG005 thermoregulator
4. OCDS008 digital chronothermostat (in association with OTRG005 thermoregulator)
5. Genius software for remote management of gas unit heaters (in association with OTRG005 thermoregulator)
6. External request



Control systems 3, 4 and 5 manage automatically the power modulation of the unit on two power levels.

4.4.1 OCDS012 1-key basic control

The control must be installed on the wall in a suitable position, using expansion screws.



How to connect the OCDS012 1-key basic control

1. Access the connection terminal block according to Procedure 4.2 p. 34.
2. Use FRO-HP 3x1 mm² cable for connection.
3. Connect the wires to the terminal block as shown in Figure 4.2 p. 35.
4. For further information refer to the instruction sheet supplied with the OCDS012 optional.



The cable may not be longer than 20 metres.

Figure 4.2 1-key basic control connection

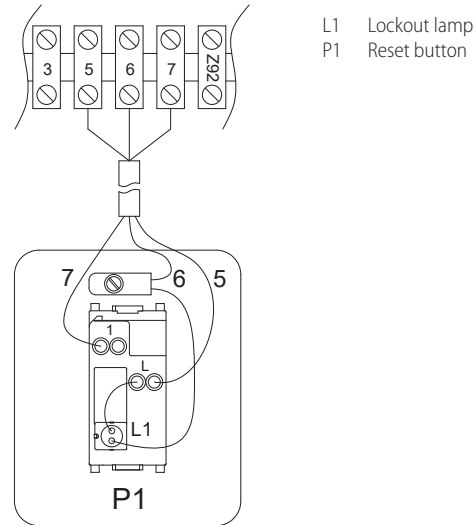

4.4.2 OCTR000 2-key basic control

The control must be installed on the wall in a suitable position, using expansion screws.



How to connect OCTR000 2-key basic control

1. Access the connection terminal block according to Procedure 4.2 p. 34.
2. Use FRO-HP 6x0,75 mm² cable (available as OCVO015 optional, with 5 m length).
3. Connect the wires to the terminal block as shown in Figure 4.3 p. 35.
4. For further information refer to the instruction sheet supplied with the OCTR000 optional.



The cable may not be longer than 20 metres.

Figure 4.3 2-key basic control connection

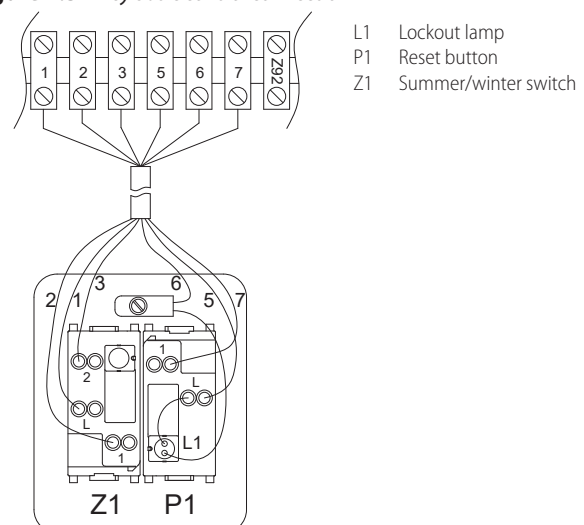

4.4.3 OTRG005 thermoregulator

The thermoregulator must be installed on the wall in a suitable position, using expansion screws.

Connection of the thermoregulator is made on the wiring terminal block located in the electrical panel inside the unit.



How to connect OTRG005 thermoregulator

1. Access the connection terminal block according to Procedure 4.2 p. 34.
2. Remove 27 and 28 temporary jumpers on the terminal block (Paragraph 1.4 p. 20).
3. Reuse electrical bridge cable 28 to make the connection between terminals NC and 2 (Figure 4.4 p. 36).
4. Use FRO-HP 7x0,75 mm² cable (available as OCVO015 optional, with 5 m length).
5. Make the other electrical connections as described in Figure 4.4 p. 36 and in Table 4.1 p. 36.
6. For further information refer to the instruction sheet supplied with the OTRG005 terminal.



The cable may not be longer than 10 metres.

Table 4.1 OTRG005 thermoregulator connection

OTRG005 thermoregulator			Next-R
J1	1	Line	1
	2	Neutral	N
J2	1	OF	5
	2	RES	7
	3	LF	6
	4	FAN	C
	5	REQ	Z91

Figure 4.4 OTRG005 thermoregulator connection

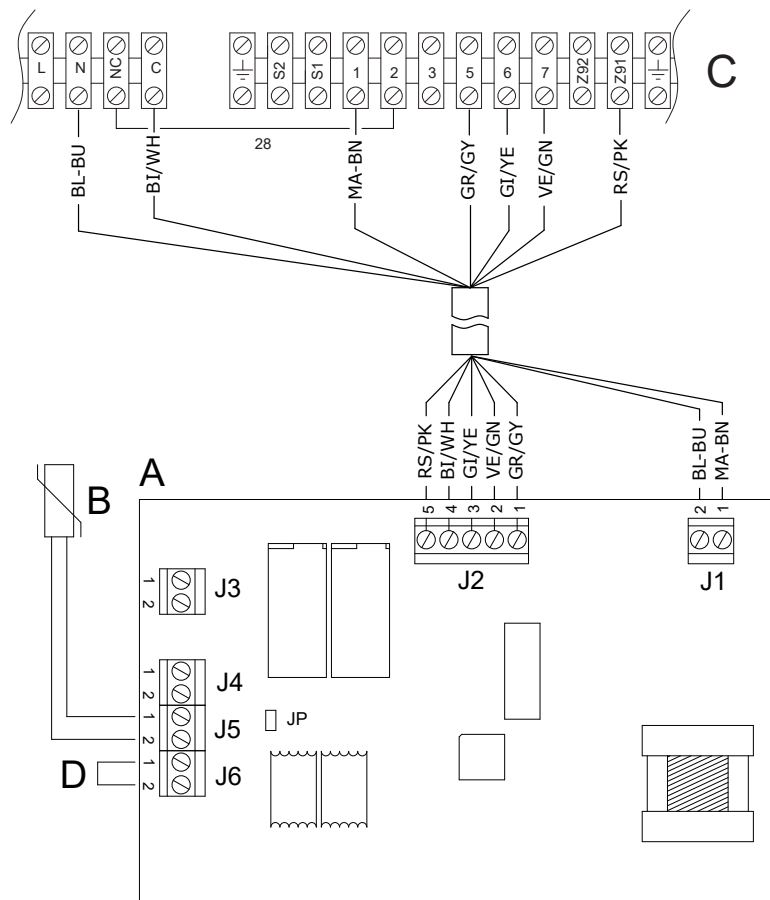

A OTRG005 thermoregulator
B Room temperature probe (supplied)

C Gas unit heater terminal block
D J6 electrical bridge

4.4.4 OCDS008 digital chronothermostat

The chronothermostat must be installed on the wall in a suitable position, using expansion screws. Connection of OCDS008 chronothermostat is made on OTRG005 thermoregulator, which is necessary for the use of the chronothermostat.



How to connect the OCDS008 digital chronothermostat

Make electrical connections as described in Figure 4.5 p. 37.



The cable may not be longer than 50 metres.

OTRG005 thermoregulator is connected as described in Paragraph 4.4.3 p. 35. To connect OCDS008 chronothermostat to OTRG005 thermoregulator, use a two-pole cable (e.g. H03VV-F) with a section between 0,5 mm² and 2,5 mm². In rooms with high electromagnetic noise, it is recommended to use shielded cable. For further information refer to the instruction sheet supplied with the OCDS008 optional.

Figure 4.5 OCDS008 digital chronothermostat connection

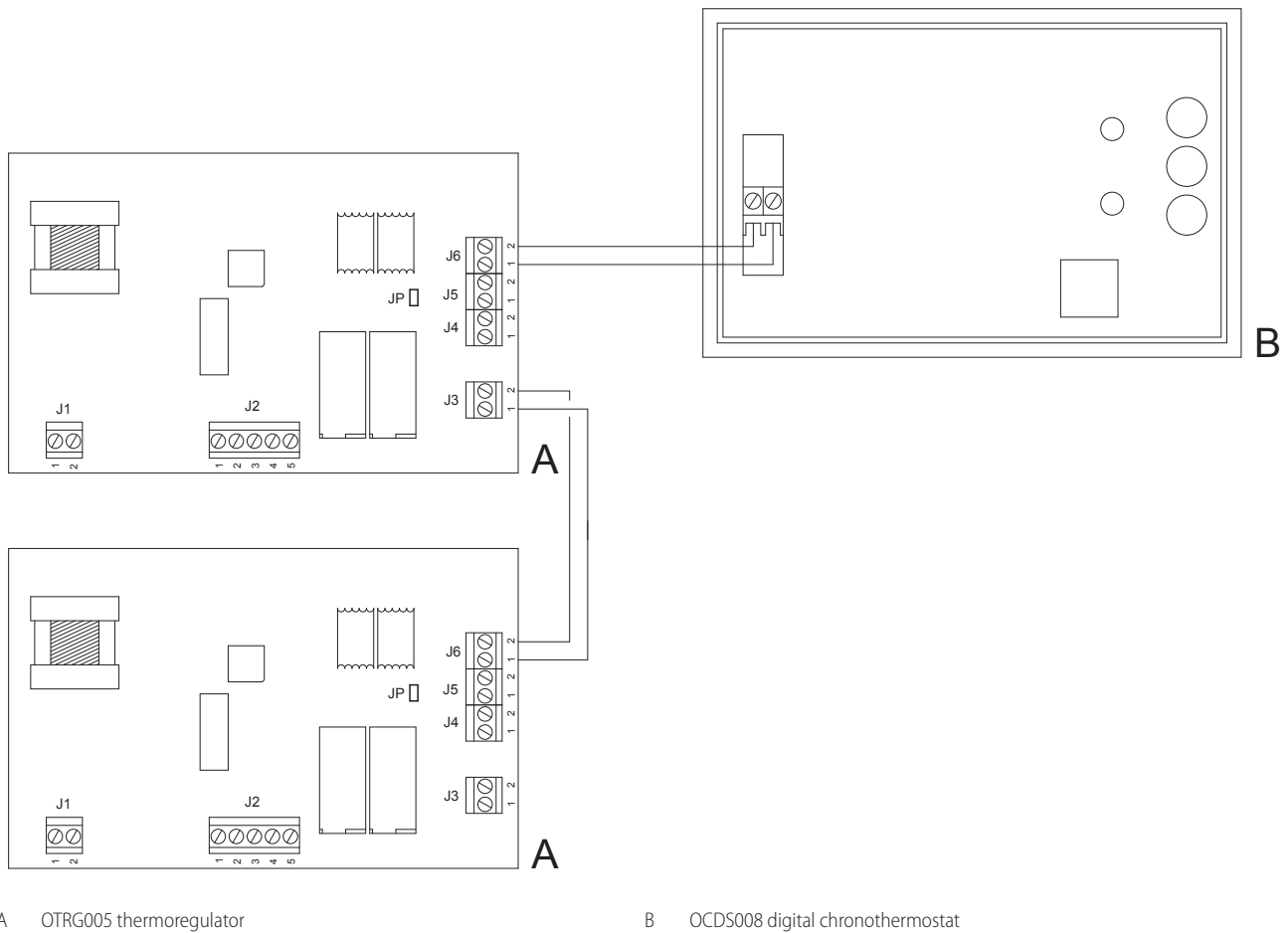

4.4.5 OSWR000 Genius software for remote management of gas unit heaters

OSWR000 Genius software for remote management of gas unit heaters comes with a PC Windows setup package and installation instructions.

The Modbus connection between the PC and OTRG005 thermoregulators must then be made, using the specific USB/RS485 converter, supplied.



How to connect OTRG005 thermoregulator

OTRG005 thermoregulator is connected as described in Paragraph 4.4.3 p. 35.



How to make Modbus connection

1. Access the J4 connection terminal block on OTRG005 thermoregulator.
2. Use unshielded 2x0,5 mm² twisted cable.
3. Connect the wires to the USB/RS485 converter terminal block as shown in Figure 4.6 p. 38.
4. Insert the USB converter into the PC. The device drivers will be downloaded and installed automatically if the PC is online.
5. For further information refer to the instruction sheet supplied with the OSWR000 Genius software.



The cable may not be longer than 1100 metres.

Figure 4.6 USB/RS485 converter connection

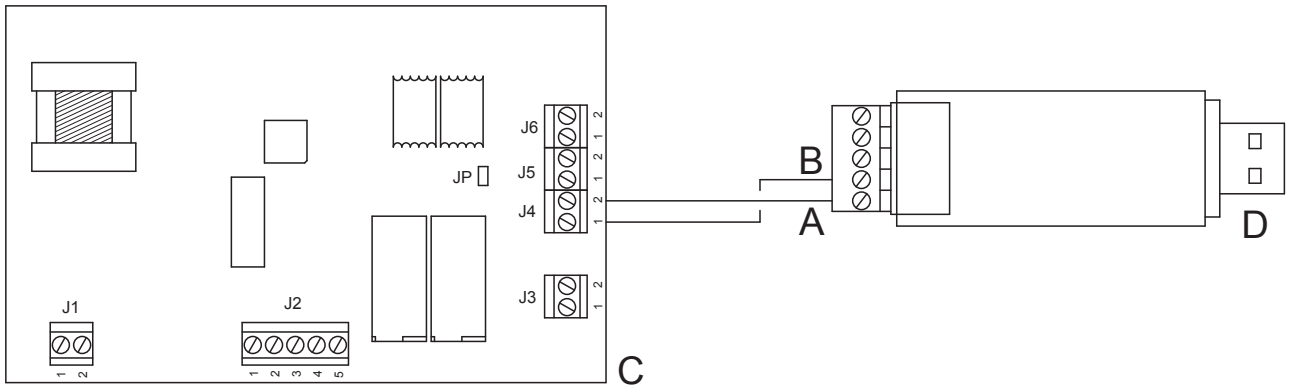

A A signal
B B signal

C OTRG005 thermoregulator
D USB/RS485 converter

4.4.6 External request

Depending on the required operation, it is required to arrange:

- ▶ Request device (e.g. thermostat, timer, switch, ...) equipped with a voltage-free NO contact, used for managing start/stop of the gas unit heater.
- ▶ Request device (switch) equipped with a changeover contact, for managing winter/summer mode operation.
- ▶ Request device (e.g. button) equipped with a voltage-free NO contact, used for managing the two gas unit heater power levels. Through the use of a 2-step thermostat or chronothermostat, it is possible to unify the gas unit heater start/stop management with the two power levels management.

For details on the position and possible presence of temporary jumpers on terminals of the unit terminal block, refer to the wiring diagrams in Paragraph 1.4 p. 20.



All the contacts for external requests of the terminal block in the electrical panel inside the unit have a 230 V voltage applied to the relative terminals.

4.4.6.1 Gas unit heater start/stop management



How to connect the external request for gas unit heater start/stop management

1. Access the electrical panel of the appliance according to the Procedure 4.2 p. 34.
2. Connect the external request, using a 2x0,75 mm² FRO-HP cable, to Z9-Z9 terminals of the gas unit heater terminal block, as shown in Figure 4.7 p. 38.



The cable may not be longer than 20 metres.

Figure 4.7 Connection of external request for gas unit heater start/stop management

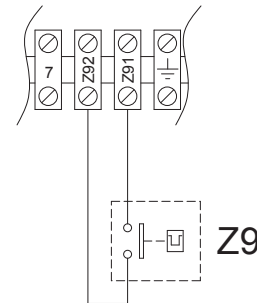

Z9 External request (e.g. thermostat, timer, switch, ...)

4.4.6.2 Summer/winter mode management



How to connect the external request for summer/winter mode management

1. Access the electrical panel of the appliance according to the Procedure 4.2 p. 34.
2. Remove the 28 temporary jumper between 1-3 terminals on the internal terminal block.
3. Connect the external request, using a 3x0,75 mm² cable, to terminals 1, 2, 3, of the gas unit heater terminal block, as shown in Figure 4.8 p. 38.



The cable may not be longer than 20 metres.

Figure 4.8 Summer/winter switch connection

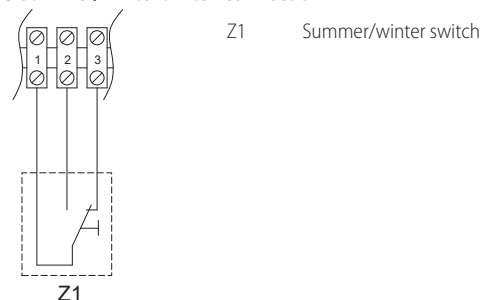

Z1 Summer/winter switch

4.4.6.3 Power level control



How to connect the external request for gas unit heater power level management

1. Access the electrical panel of the appliance according to the Procedure 4.2 p. 34.
2. Remove the 27 temporary jumper between L-C terminals on the internal terminal block.
3. Connect the external request, using a 2x0,75 mm² cable, to L-C terminals of the gas unit heater terminal block, as shown in Figure 4.9 p. 39.



Gas unit heater operates at maximum power when the L-C contact is closed, while it operates at minimum power when the L-C contact is open.



The cable may not be longer than 20 metres.

Figure 4.9 Gas unit heater power level selector switch connection

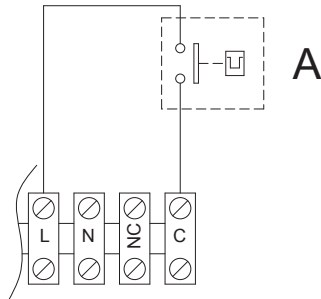

- A Gas unit heater power level selector switch:
- Closed contact: gas unit heater at maximum power
 - Open contact: gas unit heater at minimum power

4.4.6.4 2-step thermostat

With a 2-step thermostat (or chronothermostat) it is possible to combine the functions of start/stop and power level management of the gas unit heater in a single control.

Connections must be made according to the wiring diagram of the specific thermostat used (refer to the thermostat manufacturer's documentation), respecting the specifications in Paragraph 4.4.6.1 p. 38 in relation to the gas unit heater start/stop request and in Paragraph 4.4.6.3 p. 39 in relation to the gas unit heater two power level management.

4.4.6.5 Operation as destratifier

For vertical downflow gas unit heaters only, it is possible to use a thermostat, suitably positioned and adjusted, to allow the operation of the appliance's fan only (with the burner off), for thermal destratification.

This way, if the temperature measured by the thermostat in its installation point is higher than the threshold set on the thermostat itself, it will give the request to the fan only, which will push the mass of warm air downwards.

Thermostat connection is shown in Figure 4.10 p. 39.

Figure 4.10 Destratification thermostat connection

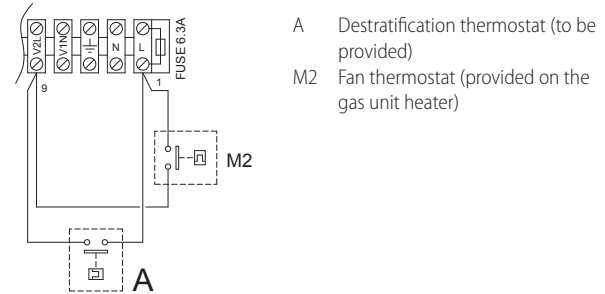

- A Destratification thermostat (to be provided)
- M2 Fan thermostat (provided on the gas unit heater)



The gas unit heater fan will be activated each time it receives the request from the destratification thermostat, regardless of any other request.

4.4.6.6 Control of multiple gas unit heaters with a single external request

Through a suitable connection to the terminals described above, it is possible to manage the specific function on more than one gas unit heater using a single external request.

In the case of centralized management of multiple gas unit heaters start/stop, advice given is to use:

- ▶ OCDS008 digital chronothermostat (described in Paragraph 1.6.5 p. 23), up to 10 gas unit heaters.
- ▶ OSWR000 Genius software (described in Paragraph 1.6.6 p. 23), up to 100 gas unit heaters.

If you do not want to use these solutions, the centralized management of start/stop can be done as described in Figure 4.11 p. 40, using a programmable timer and several room thermostats. The room thermostats serving each gas unit heater allow the gas unit heater to be activated only when the specific zone actually needs heat, avoiding wastage of energy. The programmable timer allows subordinating the gas unit heater activation, even if requested by the room thermostat, to a centralized request.

Figure 4.11 Multiple appliances wiring diagram with one programmable timer and more room thermostats

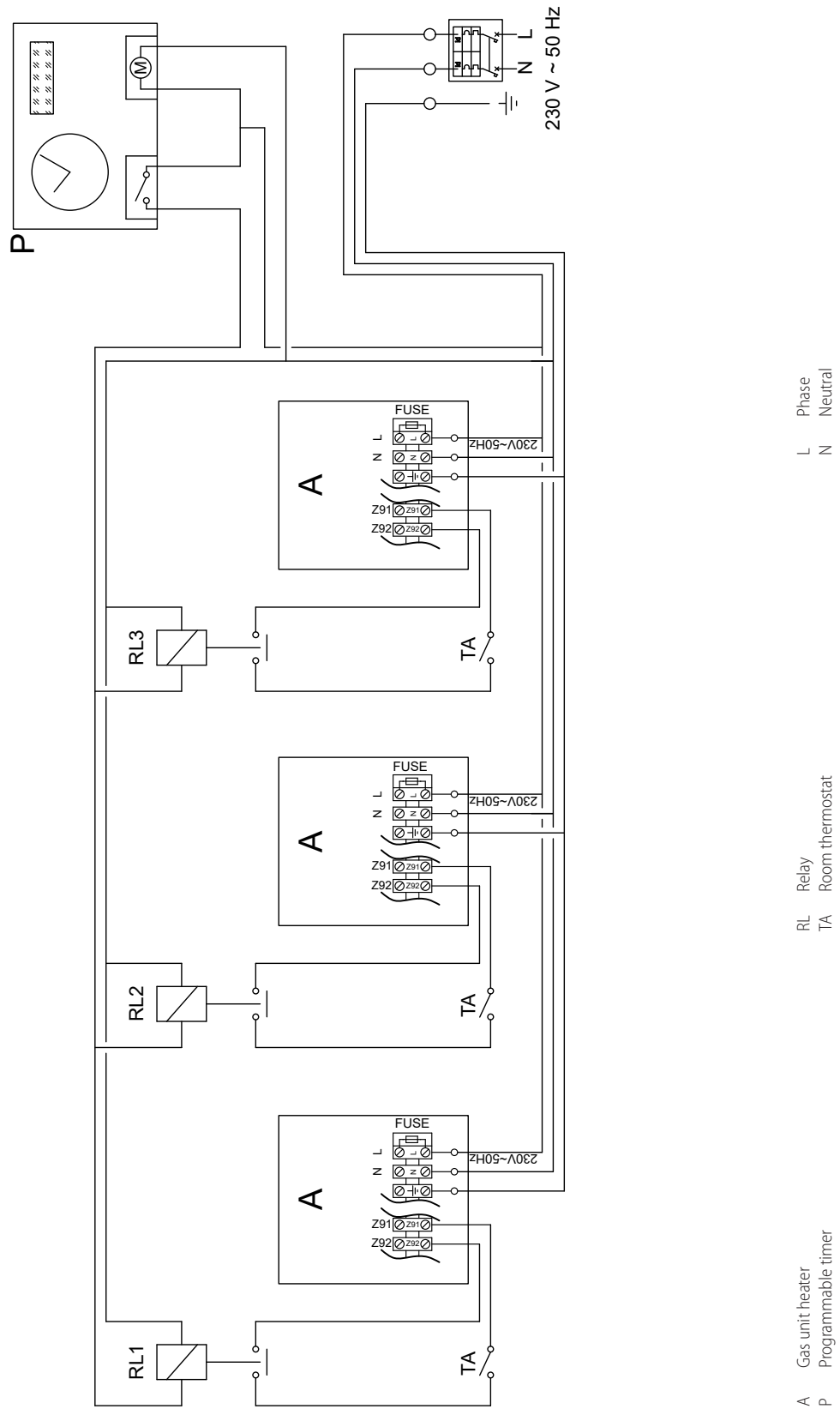

4.4.7 Positioning the control system

Install the chosen thermostat/control system according to the following guidelines:

- ▶ At about 1,5 m from the floor, protected against air draughts, direct exposure to sun rays and direct heat sources (lamps,

- hot air flow from the unit itself, etc.).
- ▶ If possible, do not place the control system on walls bordering the outside, to avoid false temperature readings and therefore affect system operation. If this is not possible, shield the control system by placing a sheet of insulating material (cork, polystyrene or other similar) between the

control system and the wall.



By following the above guidelines, unwanted starting and stopping of the system can be avoided and optimal comfort in the heated space can be guaranteed.

5 FIRST START-UP



First start-up entails checking/setting up the combustion parameters and may exclusively be carried out by a Robur TAC. NEITHER the user NOR the installation technician is authorised to perform such operations, under penalty of voiding the warranty.

The installer is obliged to carry out preliminary checks described in Paragraph 5.1 p. 41.

5.1 PRELIMINARY CHECKS



Paragraph dedicated to the installer.

5.1.1 Preliminary checks for first start-up

Upon completing installation, before contacting the TAC the installer must check:

- ▶ Electrical and gas systems suitable for the required capacities and equipped with all safety and control devices required by the regulations in force.
- ▶ Absence of leaks in the gas system.
- ▶ Type of gas for which the appliance is designed (natural gas, LPG or other gas).
- ▶ Supply gas pressure complying with the values of Table 3.1 p. 28, with max tolerance $\pm 15\%$.
- ▶ Correct operation of the flue exhaust duct.
- ▶ Combustion air intake and flue gas exhaust correctly carried out according to the regulations in force.
- ▶ Power supply mains complying with the appliance's rating plate data.
- ▶ Appliance correctly installed, according to the manufacturer's provisions.
- ▶ Front grille louvres, if present, correctly opened (Paragraph 3.4 p. 33).
- ▶ System installed in a workmanlike manner, according to national and local regulations.

5.1.2 Abnormal or hazardous installation situations

Should any abnormal or hazardous installation situations be found, the TAC shall not perform first start-up and the appliance shall not be commissioned.

These situations may be:

- ▶ Failed compliance with minimum clearances.
- ▶ Insufficient distance from combustible materials.
- ▶ Conditions that do not warrant access and maintenance in safety.
- ▶ Appliance switched on/off with the main switch, instead of the provided control device.
- ▶ Appliance defects or faults caused during transport or installation.
- ▶ Gas smell.
- ▶ Non-compliant mains gas pressure.
- ▶ Non-compliant flue gas exhaust.
- ▶ All situations that may involve operation abnormalities or are potentially hazardous.

5.1.3 Non-compliant system and corrective actions

Should the TAC find any non conformities, the user/installer is bound to perform any corrective procedures required by the TAC.

After performing the remedial actions (the installer's responsibility), if the TAC deems that safety and conformity conditions are in place, first start-up may be effected.

5.2 COMBUSTION PARAMETERS CHECK



Paragraph reserved exclusively to TACs.



The gas unit heater is supplied with the gas valve already calibrated with respect to the fuel indicated on the sticker next to the gas connection. Therefore, during the commissioning, only the CO₂ value must be checked and, only if the check is not successful, or after a gas changeover, the complete check procedure must be carried out.



The CO₂ value should be checked with the thermoformed door closed, while the gas valve should be adjusted with the thermoformed door open.



After each setting of the CO₂ value or change of power level, check the burner, which should not show any red-dened areas.



Check that the static and dynamic supply gas pressure values, with the gas unit heater running at maximum power, correspond to what is shown in Table 3.1 p. 28 (with low supply gas pressure values the CO₂ value will also be at minimum values).



If the control systems are designed so that the gas unit heater activation request depends on the room temperature, the gas unit heater may not start because the room temperature is already at requested setpoint. In this case, set the forcing for manual activation on the control system, or close contact Z9 (Z91-Z92 terminals) manually.



Remember to set contact 27 (L-C terminals) back in its original position or stop manual forcing of the power level after the conclusion of checking operations.



If it has been set, remember to disable the forcing for manual activation on the control system, or manual close of contact Z9 (Z91-Z92 terminals).

5.2.1 R15/R20/R30/R40/R50



The simple check of CO₂ values corresponds to steps 8 to 13 of the procedure below, after turning on the unit. If the check is not successful, the complete procedure must be carried out.



Figure 5.1 p. 42

1. If the appliance is running, switch it off with the applicable control system.
2. Open the thermoformed door.
3. Remove the cap over the offset adjustment screw (C) of the gas valve.
4. Screw in completely the throttle adjustment screw (D).
5. Screw in completely the offset adjustment screw (C).
6. Unscrew the throttle adjustment screw (D) as indicated in the following Tables, depending on the model and the gas type used.
7. Unscrew the offset adjustment screw (C) as indicated in the following Tables, depending on the model and the gas type used.
8. Open contact 27 (L-C terminals), or act on the power level control device to force gas unit heater operation at minimum power.
9. Switch on the gas unit heater using the provided control device.

10. After about 2 minutes from the burner ignition, the combustion control at minimum power can be carried out.
11. Ensure that the CO₂ value corresponds to the value indicated in the "Minimal heat input" column of the following Tables, according to the model and the gas type used. Otherwise, set CO₂ percentage value using the offset adjustment screw.
12. Close contact 27 (L-C terminals), or act on the power level control device to force gas unit heater operation at maximum power.
13. Ensure that the CO₂ value corresponds to the value indicated in the "Nominal heat input" column of the following Tables, according to the model and the gas type used.

If the check is successful:

14. Set contact 27 (L-C terminals) back in its original position or stop manual forcing of the power level.
15. Screw the cap back over the offset adjustment screw (C) of the gas valve.
16. Close the thermoformed door.

If the check is not successful:

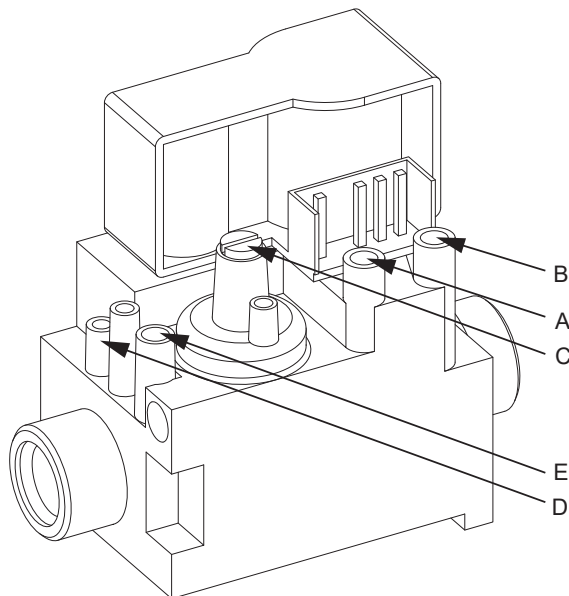

17. Repeat steps 8 to 11 to reactivate the minimum power operation; verify once again and, if necessary, correct the CO₂ value in these conditions by actuating the offset adjustment screw.
18. Repeat steps 12 and 13 to reactivate the maximum power operation; verify once again and, if necessary, correct the CO₂ value in these conditions by actuating the throttle adjustment screw.
19. Repeat steps 14 to 16 to complete the procedure.

Figure 5.1 Gas valve





- A Offset pressure intake
- B Gas mains pressure intake
- C Offset adjustment screw
- D Throttle adjustment screw
- E Throttle pressure intake

Table 5.1 R15 gas valve setting table

Gas	Gas network pressure	Screw pre-adjustment		CO ₂ percentage in flue gases	
		Throttle	Offset	Minimal heat input	Nominal heat input
Type	mbar	turns 	turns 	%	%
G20	See Table 3.1 p. 28	-10 ½	-3 ¾	8,8	9,0
G25		full open	-3	8,6	9,2
G25.1		-10 ½	-3 ¾	10,2	10,7
G25.3		full open	-3 ¾	8,6	9,2
G27		-12	-3 ¾	9,0	9,5
G2.350		full open	-3 ¾	8,6	9,1
G30		-7	-3 ¾	9,9	10,3
G31		full open	-3 ¾	10,0	10,5
LPG		-9	-3 ¾	9,9	10,5



A tolerance of $\pm 0,3\%$ is applied to all values of CO₂ percentage in fumes.

Table 5.2 R20 gas valve setting table

Gas	Gas network pressure	Screw pre-adjustment		CO ₂ percentage in flue gases	
		Throttle	Offset	Minimal heat input	Nominal heat input
Type	mbar	turns 	turns 	%	%
G20	See Table 3.1 p. 28	-3 ¾	-3 ¾	8,6	9,2
G25		full open	-3 ¾	8,7	9,3
G25.1		-5 ¼	-3 ¾	10,6	11,1
G25.3		-7 ½	-3 ¾	8,5	9,1
G27		-5 ½	-3 ¾	9,1	9,6
G2.350		full open	-3 ¾	8,8	9,3
G30		-2 ¼	-3 ¾	9,9	10,3
G31		full open	-3 ¾	10,5	11,0
LPG		-2 ¾	-3 ¾	10,3	10,7



A tolerance of $\pm 0,3\%$ is applied to all values of CO₂ percentage in fumes.

Table 5.3 R30 gas valve setting table

Gas	Gas network pressure	Screw pre-adjustment		CO ₂ percentage in flue gases	
		Throttle	Offset	Minimal heat input	Nominal heat input
Type	mbar	turns 	turns 	%	%
G20	See Table 3.1 p. 28	-6 ½	-3 ¾	8,2	8,5
G25		full open	-3 ¾	8,5	9,0
G25.1		-13 ½	-3 ¾	9,6	10,1
G25.3		-21	-3 ¾	8,5	9,0
G27		-6 ¾	-3 ¾	8,5	9,0
G2.350		full open	-3 ½	8,5	9,0
G30		-8	-3 ¾	9,5	11,0
G31		full open	-3	9,1	9,5
LPG		-14	-3 ½	9,0	9,6

A tolerance of $\pm 0,3\%$ is applied to all values of CO₂ percentage in fumes.

Table 5.4 R40 gas valve setting table

Gas	Gas network pressure	Screw pre-adjustment		CO ₂ percentage in flue gases	
		Throttle	Offset	Minimal heat input	Nominal heat input
Type	mbar	turns 	turns 	%	%
G20	See Table 3.1 p. 28	-5	-3 ¾	8,6	9,2
G25		full open	-3 ¼	8,5	9,0
G25.1		-8 ¼	-3 ¾	9,6	10,2
G25.3		-12	-4	8,5	9,0
G27		-8 ½	-3 ¾	8,6	9,1
G2.350		full open	-3 ¾	8,5	9,0
G30		-8	-3 ¾	9,5	10,0
G31		full open	-3	9,6	10,1
LPG		-10 ¼	-4	9,5	10,1

A tolerance of $\pm 0,3\%$ is applied to all values of CO₂ percentage in fumes.

Table 5.5 R50 gas valve setting table

Gas	Gas network pressure	Screw pre-adjustment		CO ₂ percentage in flue gases	
		Throttle	Offset	Minimal heat input	Nominal heat input
Type	mbar	turns ↻	turns ↻	%	%
G20	See Table 3.1 p. 28	-14	-3 ¾	8,6	9,0
G25		full open	-3 ¾	8,5	9,0
G25.1		-16 ¾	-3 ¾	10,0	10,5
G25.3		full open	-3 ¾	8,6	9,2
G27		-16	-3 ¾	8,6	9,0
G2.350		full open	-3 ¾	8,6	9,1
G30		-4 ½	-3 ¾	9,9	10,5
G31		full open	-3 ¾	9,5	10,0
LPG		-14 ¼	-3 ¾	9,7	10,3

A tolerance of ±0,3% is applied to all values of CO₂ percentage in fumes.

5.2.2 R60/R80



The simple check of CO₂ values corresponds to steps 6 to 12 of the procedure below, after turning on the appliance. If the check is not successful, the complete procedure must be carried out.



Figure 5.2 p. 44

1. If the appliance is running, switch it off with the applicable control system.
2. Open the thermoformed door.
3. Remove the cap over the offset adjustment screw (C) of the gas valve.
4. Screw in completely the offset adjustment screw (C).
5. Unscrew the offset adjustment screw (C) as indicated in the following Tables, depending on the model and the gas type used.
6. Open contact 27 (L-C terminals), or act on the power level control device to force gas unit heater operation at minimum power.
7. Switch on the gas unit heater using the provided control device.
8. After about 2 minutes from the burner ignition, the combustion control at minimum power can be carried out.
9. Ensure that the CO₂ value corresponds to the value indicated in the "Minimal heat input" column of the following Tables, according to the model and the gas type used. Otherwise, set CO₂ percentage value using the offset adjustment screw.
10. Close contact 27 (L-C terminals), or act on the power level control device to force gas unit heater operation at maximum power.
11. After about 2 minutes, the combustion control at maximum power can be carried out.
12. Ensure that the CO₂ value corresponds to the value indicated in the "Nominal heat input" column of the following Tables, according to the model and the gas type used.

If the check is successful:

13. Set contact 27 (L-C terminals) back in its original position or stop manual forcing of the power level.
14. Screw the cap back over the offset adjustment screw (C) of the gas valve.
15. Close the thermoformed door.

If the check is not successful:

16. Repeat steps 6 to 9 to reactivate the minimum power operation; verify once again and, if necessary, correct the CO₂ value in these conditions by actuating the offset adjustment screw.
17. Repeat steps 13 to 15 to complete the procedure.

Figure 5.2 Gas valve

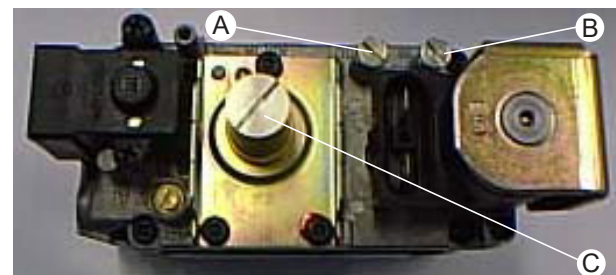

- A Offset pressure intake
- B Gas mains pressure intake
- C Offset adjustment screw

Table 5.6 R60 gas valve setting table

Gas	Gas network pressure	Screw pre-adjustment	CO ₂ percentage in flue gases	
		Offset	Minimal heat input	Nominal heat input
Type	mbar	turns ↻	%	%
G20	See Table 3.1 p. 28	-6 ¼	8,9	9,4
G25		-6 ¼	8,7	9,0
G25.1		-6 ¼	10,5	10,9
G25.3		-6 ¼	8,8	9,2
G27		-6 ¼	9,2	9,4
G2.350		-6 ¼	9,1	9,4
G30		-6 ¼	10,4	10,6
G31		-6 ¼	10,1	10,4
LPG		-6 ¼	9,8	10,2

A tolerance of ±0,3% is applied to all values of CO₂ percentage in fumes.

Table 5.7 R80 gas valve setting table

Gas	Gas network pressure	Screw pre-adjustment	CO ₂ percentage in flue gases	
		Offset	Minimal heat input	Nominal heat input
Type	mbar	turns ↻	%	%
G20	See Table 3.1 p. 28	-6 ¼	8,0	8,3
G25		-6 ¼	8,7	9,2
G25.1		-6 ¼	10,5	10,9
G25.3		-6 ¼	8,9	9,3
G27		-6 ¼	8,8	9,2
G2.350 (1)		- (1)	- (1)	- (1)
G30		-6 ¼	10,2	10,5
G31		-6 ¼	9,9	10,2
LPG		-6 ¼	9,7	10,1

1 The gas unit heater cannot operate with this type of gas.
A tolerance of ±0,3% is applied to all values of CO₂ percentage in fumes.

5.3 GAS CHANGEOVER



For gas change instructions, refer to the relevant

6 NORMAL OPERATION



This section is for the end user.



The use of the device by the end user is only permitted after the Robur authorised TAC has completed the first start-up.

6.1 WARNINGS



Prior to using the appliance carefully read the warnings in Chapter III.1 p. 4, providing important information on regulations and on safety.



First startup by TAC

First start-up may exclusively be carried out by a Robur TAC (Chapter 5 p. 41).



Never power the appliance off while it is running

NEVER power the appliance off while it is running (except in the event of danger, Chapter III.1 p. 4), since the appliance or system might be damaged.

6.2 SWITCH ON AND OFF



Routine switching on/off

The appliance may exclusively be switched on/off by means of the suitably provided control device.



Do not switch on/off with the power supply switch

Do not switch the appliance on/off with the power supply switch. This may be harmful and dangerous for the appliance and for the system.



Checks before switching on

Before switching on the appliance, ensure that:

- gas valve open
- appliance electrical power supply (main switch ON)
- connection and any necessary power supply of the control device



After a long period of unit inactivity or at the first start-up, it may be necessary to repeat the ignition operation due to the presence of air in the gas piping.

documentation.

6.2.1 OCDS012 1-key basic control and external request

Space heating activation

1. Ensure that contact 1-3 is closed by the factory installed temporary jumper. If a summer/winter selector switch (Paragraph 4.4.6.2 p. 38) has been installed, ensure that the selector switch is in the "winter" position (contact 1-3 closed).
2. Switch on Z9 contact using the provided control device (thermostat, chronothermostat or voltage-free contact).
3. After the purge time (around 40 seconds), the gas solenoid valve opens and the burner ignites.
4. When the flame is detected, the control box keeps the gas valve open.
5. Otherwise, the control unit will try the ignition again 3 times, after the appropriate purge time. If the flame does not ignite anyway, the control unit locks the unit and light the fault indicator lamp (B) on the control (Figure 6.1 p. 45).
6. In case of flame locking, press the reset button (A).



After a long period of unit inactivity or at the first start-up, it may be necessary to repeat the ignition operation due to the presence of air in the gas piping.

Figure 6.1 1-key basic control

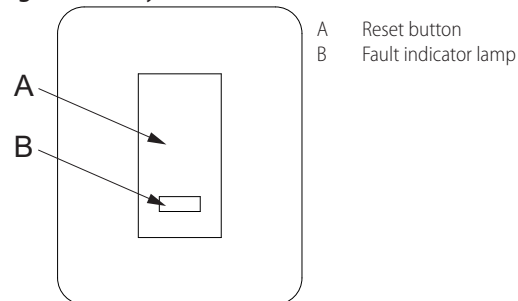

Space heating shutdown

1. Switch off space heating request by opening Z9 contact using the provided control device (thermostat, chronothermostat or voltage-free contact).
2. The burner will shut down, while the fans will continue to operate until the appliance has cooled down completely.



In case of prolonged periods of inactivity, see Paragraph 7.4 p. 47.

Ventilation activation (summer mode)

1. Close the gas valve and check power supply availability to the unit.
2. Using a suitable summer/winter selector switch (Paragraph 4.4.6.2 p. 38), select summer mode (contact 1-3 open, contact 1-2 closed). This way the fan only will start.
3. To stop the fan press again the selector switch on winter position (contact 1-2 open).



It is recommended that the heating request is deactivated during the summer season by opening contact Z9 by means of the provided control device (thermostat, chronothermostat or voltage-free contact).

6.2.2 OCTR000 2-key basic control and external request

Space heating activation

1. Set the summer/winter selector switch (A) in the winter position ❄️ (Figure 6.2 p. 46).
2. Switch on Z9 contact using the provided control device (thermostat, chronothermostat or voltage-free contact).
3. After the purge time (around 40 seconds), the gas solenoid valve opens and the burner ignites.
4. When the flame is detected, the control box keeps the gas valve open.
5. Otherwise, the control unit will try the ignition again 3 times, after the appropriate purge time. If the flame does not ignite anyway, the control unit locks the unit and light the fault indicator lamp (C) on the control (Figure 6.2 p. 46).
6. In case of flame locking, press the reset button (B).

Figure 6.2 2-keys basic control

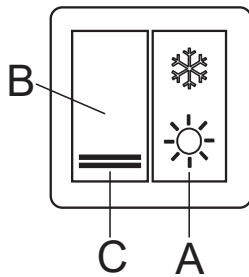

- A Summer/winter selector switch (❄️ space heating operating mode; ☀️ summer operating mode, ventilation only)
- B Reset button
- C Fault indicator lamp

Space heating shutdown

1. Switch off space heating request by opening Z9 contact using the provided control device (thermostat, chronothermostat or voltage-free contact).
2. The burner will shut down, while the fans will continue to operate until the appliance has cooled down completely.



In case of prolonged periods of inactivity, see Paragraph 7.4 p. 47.

Ventilation activation (summer mode)

1. Close the gas valve and check power supply availability to the unit.
2. Set the summer/winter selector switch (A) in the summer position ☀️ (Figure 6.2 p. 46). This way the fan only will start.
3. To stop the fan press again the selector switch on winter position ❄️.



It is recommended that the heating request is deactivated during the summer season by opening contact Z9 by means of the provided control device (thermostat, chronothermostat or voltage-free contact).

6.2.3 OTRG005 thermoregulator



Refer to the instructions in the relevant manual.

6.2.4 OCDS008 digital chronothermostat



Refer to the instructions in the relevant manual.

6.2.5 OSWR000 Genius software for remote management of gas unit heaters



Refer to the instructions in the relevant manual.

6.3 RESTARTING A LOCKED-OUT UNIT

6.3.1 Fault signals

With the exception of the flame lock-out, detailed below, all anomalies are reported only with the optional OTRG005 thermoregulator, and with the relevant controls, i.e the OCDS008 digital chronothermostat and OSWR000 Genius software.

6.3.1.1 Flame lockout

Flame lockout is signalled by closing contact 5-6 on the unit terminal block.

If an indicator lamp (which is included when using optional 1- or 2-key basic controls, see Paragraph 1.6.2 p. 22 and 1.6.3 p. 22) is connected to this contact, the lamp will glow when the contact is closed, indicating the locking status.



When multiple consecutive flame lockout signals occur, it is recommended to check that the limit thermostat has not been triggered due to overheating of the unit. If this is the case, reset the limit thermostat and check the causes of its intervention by qualified personnel (see also Paragraph 7.3 p. 47).

6.3.2 Locked-out appliance

An external intervention (reset or repair) is required due to an appliance fault.

- ▶ A reset may be enough for a temporary and provisional fault.
- ▶ For a fault or breakdown, alert the maintenance technician or TAC.

6.3.3 Reset

The flame lockout can be reset:

- ▶ Using the specific button, with the 1- or 2-key optional basic control, OTRG005 thermoregulator, OCDS008 digital chronothermostat, or OSWR000 Genius software.

Other errors that allow resetting can be reset by power cycling the unit.

6.4 EFFICIENCY

For greater appliance efficiency:

- ▶ Install horizontal flow units observing requirements on height above ground (Figure 2.2 p. 26).
- ▶ Direct the warm air flow downwards, using the horizontal louvres of the delivery grille, respecting the instructions given in Paragraph 2.3 p. 25.
- ▶ Position the thermostat/control system according to the guidelines given in Paragraph 4.4.7 p. 40.
- ▶ Program appliance activation for actual periods of use.
- ▶ Keep the fan grilles clean.
- ▶ Reduce repeated switch-ons to the minimum.

► Use a control device (e.g. OTRG005 thermoregulator, option-

al) that allows exploiting the power modulation of the unit.

7 MAINTENANCE

7.1 WARNINGS

i Correct maintenance prevents problems, assures efficiency and keeps running costs low.

i Maintenance operations described herein may exclusively be performed by the TAC or skilled maintenance technician.

! Any operation on internal components may exclusively be performed by the TAC.

i Before performing any operation, switch off the appliance by means of the control device and wait for the end of the shutdown cycle, then disconnect power and gas supply, by acting on the electrical disconnecter and gas

valve.

i The efficiency checks and every other "check and maintenance operation" (see Table 7.1 p. 47) must be performed with a frequency according to current regulations or, if more restrictive, according to the provisions set forth by the manufacturer, installer or TAC.

i Responsibility for efficiency checks, to be carried out for the aims of restricting energy consumption, lies with the system manager.

7.2 SCHEDULED ROUTINE MAINTENANCE

Perform the operations in the following Table 7.1 p. 47 on an annual basis.

Table 7.1 Scheduled routine maintenance

		Next-R	Next-G	G	K	M
Ordinary scheduled maintenance						
	clean the burner	√	√	√	√	√
	clean the ignition and flame sensor electrodes	√	√	√	√	√
	clean the fan	√	√	√	√	√
Appliance check	clean the blower/exhaust fan	√	√	√	√	√
	check the % value of CO ₂	√	√	√	√	√
	check the unit safety devices	√	√	√	√	√
	check that the condensate drain is clean	-	√	√	-	-

7.3 RESETTING THE TEMPERATURE LIMIT THERMOSTAT

The temperature limit thermostat stops the burner in case of appliance overheating.

Resetting is carried out by pressing the button on the back of the unit (detail 6 on dimensional diagrams, Paragraph 1.2 p. 8), after unscrewing the protective cap (see Figure 7.1 p. 47). Set back in place the protective cap after resetting the thermostat.

! Resetting of the temperature limit thermostat should be carried out by qualified service personnel, after removing the cause of overheating.

! The intervention of the temperature limit thermostat ALWAYS indicates an abnormal condition. Before resetting, it is therefore advisable to search for the reasons that led to the unit overheating. If frequent stops occur, contact Robur TAC.

Figure 7.1 Position of the limit thermostat reset

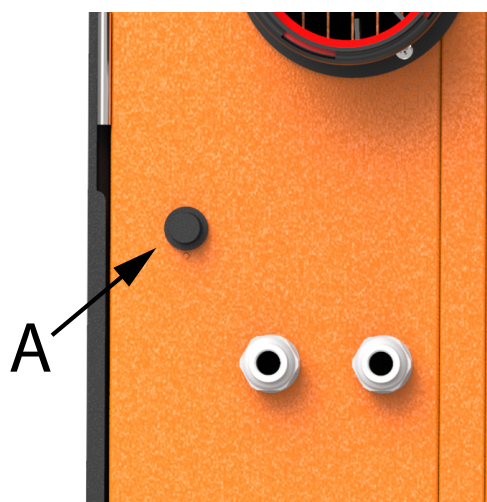

A Protective cap of the limit thermostat reset button

7.4 PERIODS OF INACTIVITY

Should you foresee to leave the appliance inactive for a long period of time, disconnect it from the electrical and gas mains.

**How to deactivate the appliance for long periods of time**

1. Switch the appliance off (Paragraph 6.2 p. 45).
2. Only when the appliance is completely off, power it off with the main switch/disconnector switch (detail GS, Figure 4.1 p. 35).
3. Close the gas valve.

**How to reactivate the appliance after long periods of inactivity**

Before reactivating the appliance, the operator/maintenance technician of the system must first of all:

- Check whether any maintenance operations are required (contact the TAC; see Paragraph 7.2 p. 47).
 - Ensure that the flue gas exhaust duct and the air intake are not obstructed.
After completing the above checks:
1. Open the gas valve and ensure there are no leaks; should gas smell be noticed, close the gas valve again, do not switch any electrical devices on and request intervention by qualified personnel.
 2. Power on with the main power supply switch (GS, Figure 4.1 p. 35).
 3. Switch on the appliance by means of the provided control device (Paragraph 6.2 p. 45).

8 APPENDICES

8.1 PRODUCT FICHE

Figure 8.1

Table 9 Information requirements for warm air heaters							
Model(s): Information to identify the model(s) to which the information relates:							R15
B ₁ warm air heater: [yes/no]							no
C ₂ warm air heater: [yes/no]							no
C ₄ warm air heater: [yes/no]							no
Type of fuel: [gas/liquid/electricity]							gas
Item	Symbol	Value	Unit	Item	Symbol	Value	Unit
Capacity				Useful efficiency			
Rated heating capacity	P _{rated,h}	14,1	kW	Useful efficiency at rated heating capacity (*)	η _{nom}	82,0	%
Minimum capacity	P _{min}	9,9	kW	Useful efficiency at minimum capacity (*)	η _{pl}	86,5	%
Electric power consumption (*)				Other items			
At rated heating capacity	e _{l,max}	0,035	kW	Envelope loss factor	F _{env}	0,0	%
At minimal capacity	e _{l,min}	0,015	kW	Ignition burner power consumption (*)	P _{ign}	0,0	kW
In standby mode	e _{l,sb}	0,000	kW	Emissions of nitrogen oxides (*)	NOx	16	mg/kWh input energy (GCV)
				Emission efficiency	η _{s,flow}	95,4	%
				Seasonal space heating energy efficiency	η _{s,h}	78,1	%
Contact details	Robur SPA Via Parigi 4/6 I-24040 Zingonia (BG)						
(*) Not required for electric warm air heaters.							

Figure 8.2

Table 9 Information requirements for warm air heaters							
Model(s): Information to identify the model(s) to which the information relates:							R20
B ₁ warm air heater: [yes/no]							no
C ₂ warm air heater: [yes/no]							no
C ₄ warm air heater: [yes/no]							no
Type of fuel: [gas/liquid/electricity]							gas
Item	Symbol	Value	Unit	Item	Symbol	Value	Unit
Capacity				Useful efficiency			
Rated heating capacity	P _{rated,h}	18,7	kW	Useful efficiency at rated heating capacity (*)	η _{nom}	82,0	%
Minimum capacity	P _{min}	12,7	kW	Useful efficiency at minimum capacity (*)	η _{pl}	86,9	%
Electric power consumption (*)				Other items			
At rated heating capacity	e _{l,max}	0,035	kW	Envelope loss factor	F _{env}	0,0	%
At minimal capacity	e _{l,min}	0,015	kW	Ignition burner power consumption (*)	P _{ign}	0,0	kW
In standby mode	e _{l,sb}	0,000	kW	Emissions of nitrogen oxides (*)	NOx	33	mg/kWh input energy (GCV)
				Emission efficiency	η _{s,flow}	94,7	%
				Seasonal space heating energy efficiency	η _{s,h}	78,0	%
Contact details	Robur SPA Via Parigi 4/6 I-24040 Zingonia (BG)						
(*) Not required for electric warm air heaters.							

Figure 8.3

Table 9 Information requirements for warm air heaters								
Model(s): Information to identify the model(s) to which the information relates:							R30	
B ₁ warm air heater: [yes/no]							no	
C ₂ warm air heater: [yes/no]							no	
C ₄ warm air heater: [yes/no]							no	
Type of fuel: [gas/liquid/electricity]							gas	
Item	Symbol	Value	Unit		Item	Symbol	Value	Unit
Capacity					Useful efficiency			
Rated heating capacity	P _{rated,h}	25,5	kW		Useful efficiency at rated heating capacity (*)	η _{nom}	82,0	%
Minimum capacity	P _{min}	16,3	kW		Useful efficiency at minimum capacity (*)	η _{pl}	87,1	%
Electric power consumption (*)					Other items			
At rated heating capacity	e _{l,max}	0,040	kW		Envelope loss factor	F _{env}	0,0	%
At minimal capacity	e _{l,min}	0,015	kW		Ignition burner power consumption (*)	P _{ign}	0,0	kW
In standby mode	e _{l,sb}	0,000	kW		Emissions of nitrogen oxides (*)	NOx	25	mg/kWh input energy (GCV)
					Emission efficiency	η _{s,flow}	94,2	%
					Seasonal space heating energy efficiency	η _{s,h}	78,0	%
Contact details	Robur SPA Via Parigi 4/6 I-24040 Zingonia (BG)							
(*) Not required for electric warm air heaters.								

Figure 8.4

Table 9 Information requirements for warm air heaters								
Model(s): Information to identify the model(s) to which the information relates:							R40	
B ₁ warm air heater: [yes/no]							no	
C ₂ warm air heater: [yes/no]							no	
C ₄ warm air heater: [yes/no]							no	
Type of fuel: [gas/liquid/electricity]							gas	
Item	Symbol	Value	Unit		Item	Symbol	Value	Unit
Capacity					Useful efficiency			
Rated heating capacity	P _{rated,h}	35,0	kW		Useful efficiency at rated heating capacity (*)	η _{nom}	82,4	%
Minimum capacity	P _{min}	22,2	kW		Useful efficiency at minimum capacity (*)	η _{pl}	86,9	%
Electric power consumption (*)					Other items			
At rated heating capacity	e _{l,max}	0,040	kW		Envelope loss factor	F _{env}	0,0	%
At minimal capacity	e _{l,min}	0,020	kW		Ignition burner power consumption (*)	P _{ign}	0,0	kW
In standby mode	e _{l,sb}	0,000	kW		Emissions of nitrogen oxides (*)	NOx	33	mg/kWh input energy (GCV)
					Emission efficiency	η _{s,flow}	94,3	%
					Seasonal space heating energy efficiency	η _{s,h}	78,0	%
Contact details	Robur SPA Via Parigi 4/6 I-24040 Zingonia (BG)							
(*) Not required for electric warm air heaters.								

Figure 8.5

Table 9 Information requirements for warm air heaters							
Model(s): Information to identify the model(s) to which the information relates:							R50
B ₁ warm air heater: [yes/no]							no
C ₂ warm air heater: [yes/no]							no
C ₄ warm air heater: [yes/no]							no
Type of fuel: [gas/liquid/electricity]							gas
Item	Symbol	Value	Unit	Item	Symbol	Value	Unit
Capacity				Useful efficiency			
Rated heating capacity	P _{rated,h}	49,0	kW	Useful efficiency at rated heating capacity (*)	η _{nom}	82,0	%
Minimum capacity	P _{min}	31,0	kW	Useful efficiency at minimum capacity (*)	η _{pl}	88,1	%
Electric power consumption (*)				Other items			
At rated heating capacity	e _{l,max}	0,040	kW	Envelope loss factor	F _{env}	0,0	%
At minimal capacity	e _{l,min}	0,020	kW	Ignition burner power consumption (*)	P _{ign}	0,0	kW
In standby mode	e _{l,sb}	0,000	kW	Emissions of nitrogen oxides (*)	NO _x	27	mg/kWh input energy (GCV)
				Emission efficiency	η _{s,flow}	93,5	%
				Seasonal space heating energy efficiency	η _{s,h}	78,0	%
Contact details	Robur SPA Via Parigi 4/6 I-24040 Zingonia (BG)						
(*) Not required for electric warm air heaters.							

Figure 8.6

Table 9 Information requirements for warm air heaters							
Model(s): Information to identify the model(s) to which the information relates:							R60
B ₁ warm air heater: [yes/no]							no
C ₂ warm air heater: [yes/no]							no
C ₄ warm air heater: [yes/no]							no
Type of fuel: [gas/liquid/electricity]							gas
Item	Symbol	Value	Unit	Item	Symbol	Value	Unit
Capacity				Useful efficiency			
Rated heating capacity	P _{rated,h}	62,8	kW	Useful efficiency at rated heating capacity (*)	η _{nom}	82,0	%
Minimum capacity	P _{min}	40,4	kW	Useful efficiency at minimum capacity (*)	η _{pl}	87,8	%
Electric power consumption (*)				Other items			
At rated heating capacity	e _{l,max}	0,050	kW	Envelope loss factor	F _{env}	0,0	%
At minimal capacity	e _{l,min}	0,030	kW	Ignition burner power consumption (*)	P _{ign}	0,0	kW
In standby mode	e _{l,sb}	0,000	kW	Emissions of nitrogen oxides (*)	NO _x	42	mg/kWh input energy (GCV)
				Emission efficiency	η _{s,flow}	93,6	%
				Seasonal space heating energy efficiency	η _{s,h}	78,0	%
Contact details	Robur SPA Via Parigi 4/6 I-24040 Zingonia (BG)						
(*) Not required for electric warm air heaters.							

Figure 8.7

Table 9 Information requirements for warm air heaters								
Model(s): Information to identify the model(s) to which the information relates:							R80	
B ₁ warm air heater: [yes/no]							no	
C ₂ warm air heater: [yes/no]							no	
C ₄ warm air heater: [yes/no]							no	
Type of fuel: [gas/liquid/electricity]							gas	
Item	Symbol	Value	Unit		Item	Symbol	Value	Unit
Capacity					Useful efficiency			
Rated heating capacity	P _{rated,h}	76,4	kW		Useful efficiency at rated heating capacity (*)	η _{nom}	82,0	%
Minimum capacity	P _{min}	52,6	kW		Useful efficiency at minimum capacity (*)	η _{pl}	87,8	%
Electric power consumption (*)					Other items			
At rated heating capacity	e _{l,max}	0,050	kW		Envelope loss factor	F _{env}	0,0	%
At minimal capacity	e _{l,min}	0,030	kW		Ignition burner power consumption (*)	P _{ign}	0,0	kW
In standby mode	e _{l,sb}	0,000	kW		Emissions of nitrogen oxides (*)	NOx	41	mg/kWh input energy (GCV)
					Emission efficiency	η _{s,flow}	93,8	%
					Seasonal space heating energy efficiency	η _{s,h}	78,0	%
Contact details	Robur SPA Via Parigi 4/6 I-24040 Zingonia (BG)							
(*) Not required for electric warm air heaters.								

Figure 8.8

Table 9 Information requirements for warm air heaters								
Model(s): Information to identify the model(s) to which the information relates:							R30 C	
B ₁ warm air heater: [yes/no]							no	
C ₂ warm air heater: [yes/no]							no	
C ₄ warm air heater: [yes/no]							no	
Type of fuel: [gas/liquid/electricity]							gas	
Item	Symbol	Value	Unit		Item	Symbol	Value	Unit
Capacity					Useful efficiency			
Rated heating capacity	P _{rated,h}	25,5	kW		Useful efficiency at rated heating capacity (*)	η _{nom}	82,0	%
Minimum capacity	P _{min}	16,3	kW		Useful efficiency at minimum capacity (*)	η _{pl}	87,1	%
Electric power consumption (*)					Other items			
At rated heating capacity	e _{l,max}	0,040	kW		Envelope loss factor	F _{env}	0,0	%
At minimal capacity	e _{l,min}	0,015	kW		Ignition burner power consumption (*)	P _{ign}	0,0	kW
In standby mode	e _{l,sb}	0,000	kW		Emissions of nitrogen oxides (*)	NOx	25	mg/kWh input energy (GCV)
					Emission efficiency	η _{s,flow}	94,2	%
					Seasonal space heating energy efficiency	η _{s,h}	78,0	%
Contact details	Robur SPA Via Parigi 4/6 I-24040 Zingonia (BG)							
(*) Not required for electric warm air heaters.								

Figure 8.9

Table 9 Information requirements for warm air heaters							
Model(s): Information to identify the model(s) to which the information relates:							R40 C
B ₁ warm air heater: [yes/no]							no
C ₂ warm air heater: [yes/no]							no
C ₄ warm air heater: [yes/no]							no
Type of fuel: [gas/liquid/electricity]							gas
Item	Symbol	Value	Unit	Item	Symbol	Value	Unit
Capacity				Useful efficiency			
Rated heating capacity	P _{rated,h}	35,0	kW	Useful efficiency at rated heating capacity (*)	η _{nom}	82,4	%
Minimum capacity	P _{min}	22,2	kW	Useful efficiency at minimum capacity (*)	η _{pl}	87,0	%
Electric power consumption (*)				Other items			
At rated heating capacity	e _{l,max}	0,040	kW	Envelope loss factor	F _{env}	0,0	%
At minimal capacity	e _{l,min}	0,020	kW	Ignition burner power consumption (*)	P _{ign}	0,0	kW
In standby mode	e _{l,sb}	0,000	kW	Emissions of nitrogen oxides (*)	NO _x	33	mg/kWh input energy (GCV)
				Emission efficiency	η _{s,flow}	94,3	%
				Seasonal space heating energy efficiency	η _{s,h}	78,0	%
Contact details	Robur SPA Via Parigi 4/6 I-24040 Zingonia (BG)						
(*) Not required for electric warm air heaters.							

Figure 8.10

Table 9 Information requirements for warm air heaters							
Model(s): Information to identify the model(s) to which the information relates:							R50 C
B ₁ warm air heater: [yes/no]							no
C ₂ warm air heater: [yes/no]							no
C ₄ warm air heater: [yes/no]							no
Type of fuel: [gas/liquid/electricity]							gas
Item	Symbol	Value	Unit	Item	Symbol	Value	Unit
Capacity				Useful efficiency			
Rated heating capacity	P _{rated,h}	44,6	kW	Useful efficiency at rated heating capacity (*)	η _{nom}	82,0	%
Minimum capacity	P _{min}	30,3	kW	Useful efficiency at minimum capacity (*)	η _{pl}	88,1	%
Electric power consumption (*)				Other items			
At rated heating capacity	e _{l,max}	0,040	kW	Envelope loss factor	F _{env}	0,0	%
At minimal capacity	e _{l,min}	0,020	kW	Ignition burner power consumption (*)	P _{ign}	0,0	kW
In standby mode	e _{l,sb}	0,000	kW	Emissions of nitrogen oxides (*)	NO _x	27	mg/kWh input energy (GCV)
				Emission efficiency	η _{s,flow}	94,2	%
				Seasonal space heating energy efficiency	η _{s,h}	78,6	%
Contact details	Robur SPA Via Parigi 4/6 I-24040 Zingonia (BG)						
(*) Not required for electric warm air heaters.							

Figure 8.11

Table 9 Information requirements for warm air heaters								
Model(s): Information to identify the model(s) to which the information relates:							R80 C	
B ₁ warm air heater: [yes/no]							no	
C ₂ warm air heater: [yes/no]							no	
C ₄ warm air heater: [yes/no]							no	
Type of fuel: [gas/liquid/electricity]							gas	
Item	Symbol	Value	Unit	Item	Symbol	Value	Unit	
Capacity				Useful efficiency				
Rated heating capacity	P _{rated,h}	76,4	kW	Useful efficiency at rated heating capacity (*)	η _{nom}	82,0	%	
Minimum capacity	P _{min}	52,6	kW	Useful efficiency at minimum capacity (*)	η _{pl}	87,8	%	
Electric power consumption (*)				Other items				
At rated heating capacity	e _{l,max}	0,050	kW	Envelope loss factor	F _{env}	0,0	%	
At minimal capacity	e _{l,min}	0,030	kW	Ignition burner power consumption (*)	P _{ign}	0,0	kW	
In standby mode	e _{l,sb}	0,000	kW	Emissions of nitrogen oxides (*)	NO _x	41	mg/kWh input energy (GCV)	
				Emission efficiency	η _{s,flow}	93,8	%	
				Seasonal space heating energy efficiency	η _{s,h}	78,0	%	
Contact details	Robur SPA, Via Parigi 4/6, I-24040 Zingonia (BG)							
(*) Not required for electric warm air heaters.								

EU DECLARATION OF CONFORMITY (DOC)

We

Company name	Robur S.p.A.
Address	via Parigi 4/6
Postcode and City	24040 Verdellino/Zingonia (BG) Italy
Telephone number and fax	+39 035 888111 - F +39 035 884165
E-Mail	export@robur.it

declare that the DoC is issued under our sole responsibility and belongs to the following product:

Appliance / Product	Gas-fired air heaters
Trade Mark / Commercial Brand	Robur
Type	Next-R
Models	R15, R20, R30, R40, R50, R60, R80, R30 C, R40 C, R50 C, R80 C, R30 VERTICAL, R40 VERTICAL, R50 VERTICAL

The object of the declaration described above is in conformity with the relevant Union harmonization legislation:

Regulation on appliances burning gaseous fuels (GAR)	(EU) 2016/426
Others applicable Union legislation:	
Low Voltage Directive (LVD)	2014/35/EU
Electromagnetic Compatibility Directive (EMC)	2014/30/EU
Ecodesign requirements regulation	2281/2016/EU
The following harmonized standards and technical specifications have been applied:	
Domestic and non-domestic gas-fired forced convection air heaters for space heating not exceeding a net heat input of 300 kW	EN 17082:2019
Notified Body	Identification number as Notified Body
IMQ S.p.A.	0051
EU Type Examination Certificate (Pin-CE)	51AT1449

Signed for and on behalf of:

Robur S.p.A. via Parigi 4/6 - Verdellino/Zingonia (BG)	31/08/2023	Jvan Benzoni - R&D Director 
place of issue	date of issue	nome, function, signature

coscienza ecologica caring for the environment

Robur S.p.A. tecnologie avanzate per riscaldamento e climatizzazione advanced heating and cooling technologies
www.robur.it robur@robur.it via Parigi 4/6 24040 Verdellino/Zingonia (BG) Italy Tel. +39 035.888.111 Fax +39 035.884.165
capitale sociale € 2.028.000,00 i.v. iscritta al Registro Imprese di Bergamo n.154968 codice fiscale/partita iva 00373210160
V.A.T. code IT 00373210160 società soggetta all'attività di direzione e coordinamento di Fin Robur S.r.l.

Robur mission

Robur is dedicated to dynamic progression in research, development and promotion of safe, environmentally-friendly, energy-efficiency products, through the commitment and caring of its employees and partners.



caring for the environment

Robur S.p.A.
advanced technologies
for air conditioning
via Parigi 4/6
24040 Verdellino/Zingonia (BG) Italy
+39 035 888111 - F +39 035 884165
www.robur.com export@robur.it

